

KTH5702 series

Low power, high accuracy 2D Hall rotary position sensor

COMNTEK

1 Features

- Integrated highly matched 2D (X-axis, Y-axis) Hall sensor.
- Integrated multi-level low power consumption, high-precision zero drift operational amplifier, and high-precision 16Bit ADC.
- Integrated CORDIC algorithm module, 16bit absolute angle position output.
- Support absolute position detection with an angle output range of up to 360°
- The working range of the horizontal component of magnetic flux density is $\pm 130\text{mT}$. Note1
- SPI or I2C Optional Communication Interface
- Support Wake-up and Measurement Trigger Mode.
- Working Voltage 2.8V ~ 5.5V
- The IO power supply voltage can be as low as 1.8V
- Working Temperature $-40^{\circ}\text{C} \sim +85^{\circ}\text{C}$

Note1: A planar magnetic field greater than 20mT is recommended.

2 Typical Application

- Knobs, Smart Toys
- 2D Position Angle Detection
- Audio & Lighting & Home Appliances
- Instrumentation

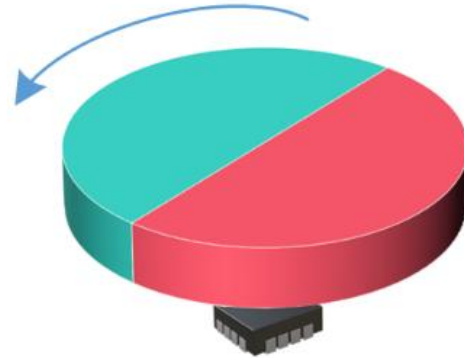

3 Overview

KTH5702 is a highly matched 2D (X-axis, Y-axis) Hall sensor; Low power consumption, low noise, high precision zero drift op amp; High performance, low impedance MUX; Integrated high-precision 16Bit ADC, digital output of rotation position angle sensor chip. The communication interface SPI or I2C is optional, and the external host can read out the measurement data in SPI or I2C modes.

KTH5702 supports a variety of operating modes such as Continuous Sensing Mode, Wake-up & Sleep Mode and Single Conversion Mode, which are suitable for different application scenarios.

KTH5702 Integrated high-efficiency, low-power CORDIC algorithm module supports the angular output of the plane and supports angle threshold detection. With high integration and flexible application, it is widely applicable to various scenarios.

KTH5702 series



Low power, high accuracy 2D Hall rotary position sensor

4 Functional Diagram

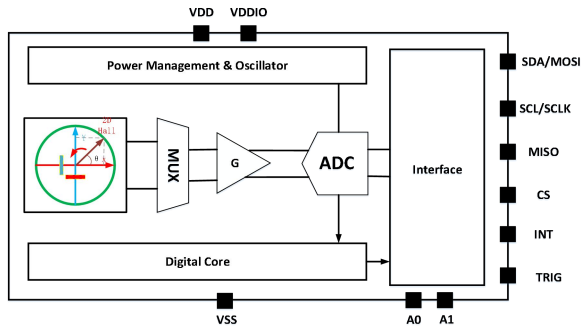

Device Information

Model	Package	Package Size (nominal)
KTH5702	QFN3x3-16L	3.00mm x 3.00mm

Catalog

1 Features	1	12 SPI Communication Mode	17
2 Typical Application	1	13 I2C Communication Mode	19
3 Overview	1	14 Special Pin Description	20
4 Functional Diagram	2	15 Read and Write Register Description	20
5 Pin Configuration	4	15.1 SPI Communication	20
6 Specifications	5	15.2 I2C Communication	21
6.1 Absolute Parameters	5	16 Register Map Description	23
6.2 Recommend Working Conditions	5	17 Reference Circuit	27
6.3 Electrical Characteristics	5	17.1 SPI	27
6.4 Magnetic Properties	5	17.2 I2C	28
6.5 Timing Parameter	6	19 Order Information	29
7 Rotate Position Angle Output	6	20 Strap and Reel Information	30
8 Measurement Mode Description	8		
8.1 Continuous Sensing Mode	8		
8.2 Wake-up & Sleep Mode	9		
8.3 Single Conversion Mode	10		
8.4 Idle Mode	11		
9 Reset	13		
10 Operating Status Description	14		
11 Data Read Frame	15		
11.1 Read Back Method	16		

5 Pin Configuration

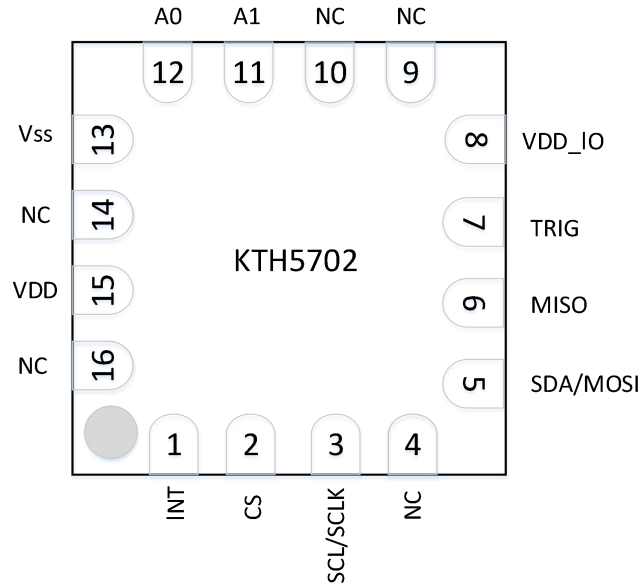

Figure 5-1. QFN3x3 16-Pin Top view

Table 5-1. Pin Configuration and Functions

Pin No.	Name	Description	Type
1	INT	Data Ready or Wake-up & Sleep Mode Interrupt Signal	Output
2	CS	In I2C communication protocol, pull up to VDD_IO In SPI communication protocol, controlled by SPI master, the low level is effective	Input
3	SCL/SCLK	I2C or SPI Clock Signal	Input
5	SDA/MOSI	I2C data input and output port SPI Data, Master Output Slave Input	Input/Output
6	MISO	SPI Data, Master Input Slave Output When using only 3-wire SPI data transmission, it is necessary to short circuit connect the MISO and MOSI	Output
7	TRIG	TRIG single measurement signal	Input/Output
8	VDD_IO	IO Power Supply	Power Supply
11	A1	I2C Address Input Port A1	Input
12	A0	I2C Address Input Port A0	Input
13	VSS	Ground	Ground
15	VDD	Power Supply	Power Supply
Other	NC	Not Connect	Non

KTH5702 series



Low power, high accuracy 2D Hall rotary position sensor

6 Specifications

The following parameters are measured at room temperature of 25 °C.

6.1 Absolute Parameters

Parameter	Description	Min.	Max.	Unit
V _{DD_MAX}	Maximum Supply Voltage	-0.3	6	V
V _{DD_IO_MAX}	Maximum Digital IO Supply Voltage	-0.3	6	V
T _{storage}	Maximum Storage Temperature		150	°C
V _{ESD}	ESD (HBM)		±5K	V

Table 6-1

6.2 Recommend Working Conditions

Parameter	Description	Min.	Typ.	Max.	Unit
V _{DD}	Supply Voltage	2.8	3.3	5.5	V
V _{DD_IO}	Digital IO Supply Voltage	1.8		V _{DD}	V
V _{IH}	Input High Level Voltage	0.75			V _{DD_IO}
V _{IL}	Input Low Level Voltage			0.25	V _{DD_IO}
T _{OPERATION}	Operating Temperature	-40	25	85	°C

Table 6-2

6.3 Electrical Characteristics

Parameter	Description	Condition	Min.	Typ.	Max.	Unit
V _{DD}	Supply Voltage		2.8	3.3	5.5	V
V _{DD_IO}	Digital IO Supply Voltage		1.8		V _{DD}	V
I _{DD,CONVXY}	Measure Peak Current	VDD=3.3V		4.89		mA
I _{DD,STBY}	Continuous Sensing Mode Standby Current			61.7		μ A
I _{DD,WAKE_STBY}	Wake-up & Sleep Mode Standby Current			2.4		μ A
I _{DD,IDLE}	Idle State Current			1.4		μ A

Table 6-3

6.4 Magnetic Properties

Parameter	Description	Condition	Min.	Typ.	Max.	Unit
Mxy	Magnetic Field Linear Range	Gain=20	-130		130	mT

KTH5702 series



Low power, high accuracy 2D Hall rotary position sensor

$N_{RMSAngle}$	Angular Output Noise	@B=20mT magnOsr=0 digCtrl=0		0.98		Degree
$N_{RMSAngle}$	Angular Output Noise	@B=20mT magnOsr=1 digCtrl=0		0.28		Degree
$N_{RMSAngle}$	Angular Output Noise	@B=20mT magnOsr=3 digCtrl=0		0.128		Degree
$N_{RMSAngle}$	Angular Output Noise	@B=20mT magnOsr=3 digCtrl=3		0.065		Degree

Table 6-4

The above parameters are measured at 25°C.

6.5 Timing Parameter

Parameter	Description	Min.	Typ.	Max.	Unit
T_{start}	Start Up Time		4		ms
T_{CONVM}	Single axis magnetic field measurement time (programmable)	165		33349	μs
		$69+32*2^{magnOsr} * (2+2^{digCtrl})$			μs
T_{CONV_END}	The time between the end of the measurement and the time when the analog enable is turned off		108		μs
T_{active}	Time from IDLE to ACTIVE		220		μs
$T_{Continuous}$	When measTime=0, the time to complete a measurement when the chip is in Continuous Sensing Mode	$m*T_{CONVM} + T_{CONV_END}$			μs
T_{wakeUp}	When measTime=0, the time to complete a measurement when the chip is in Wake-up & Sleep Mode	$m*T_{CONVM} + T_{CONV_END}$			μs
T_{single}	Time from turns on the Single Conversion Mode to complete one single measurement	$T_{active} + m*T_{CONVM} + T_{CONV_END}$			μs

Table 6-5

The above parameters are measured at 25°C.

Note: The default value in the table above is m=2.

7 Rotate Position Angle Output

KTH5702 measures the magnetic flux density component in the X and Y axis directions through the 2D (X-axis, Y-axis) Hall sensor, and calculates the two-axis magnetic flux density through the CORDIC algorithm to obtain the XY

KTH5702 series



Low power, high accuracy 2D Hall rotary position sensor

plane angle and absolute rotation position output.

Note:

•The horizontal flux density component of the magnetic field in the X and Y horizontal directions described above is 20mT, without considering the Hall device and signal chain offset, temperature drift, and noise effects.

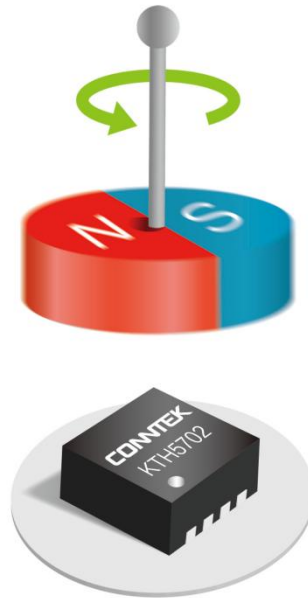
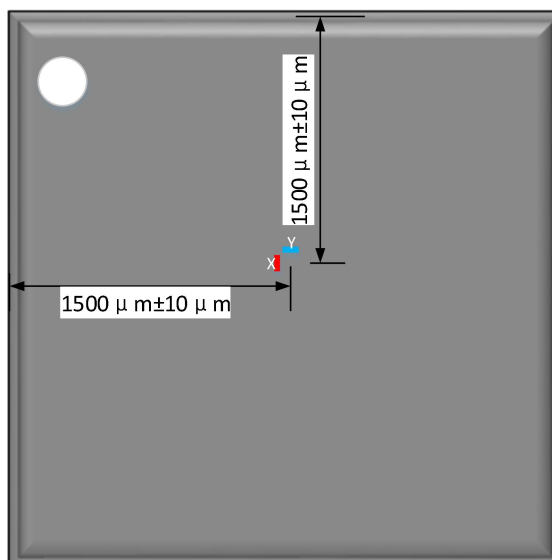

Figure 7-1. Absolute rotate position measurement diagram



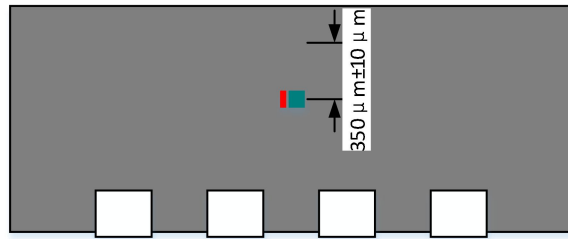

Figure 7-2. The relative position of each axis Hall element within the package

8 Measurement Mode Description

KTH5702 supports a variety of working modes. This product can be used in three modes: Continuous Sensing Mode, Wake-up & Sleep Mode, Single Conversion Mode.

Measurement Function	Function Introduction
Continuous Sensing Mode	Continuously measures the BA channel
Wake-up & Sleep Mode	When the current measurement item A is greater than the angle setting in the corresponding register, the chip sets the INT pin to 1
Single Conversion Mode	Make one measurement of the BA channel
Idle Mode	Exit the current mode and enter an idle state

Table 8-1

8.1 Continuous Sensing Mode

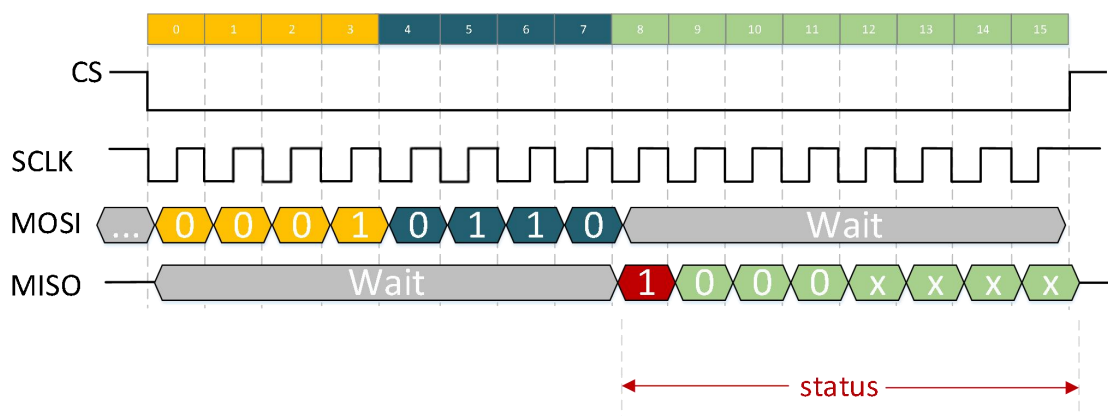

Figure 8-1. Continuous Sense Mode SPI Communication Diagram

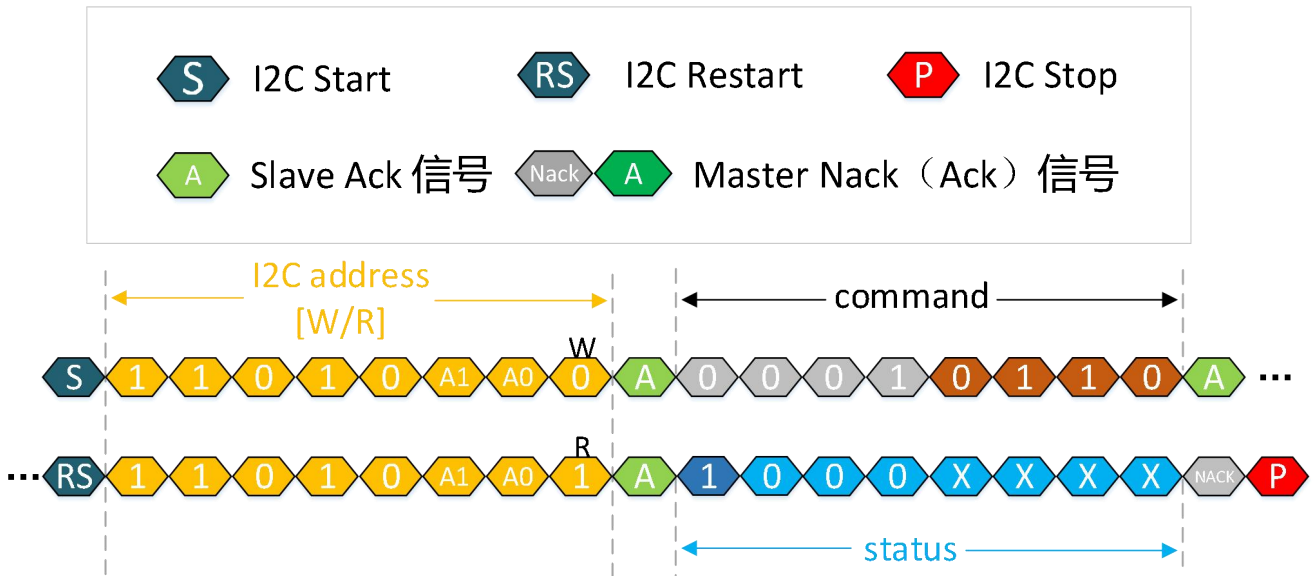

Figure 8-2. Continuous Sensing Mode I2C Communication Diagram

After the host sends a command for continuous sensing mode to the chip, the chip continues to measure the measurement item (BA) until the host sends an idle mode command to the chip.

When continuous measurement of rotation angle is required and power consumption requirements are not stringent, continuous sensing mode is recommended.

When the chip is in continuous sensing mode, intermittent measurement is used to reduce chip power consumption. The chip will automatically and continuously open the measurement of the corresponding measurement item, and the interval between two adjacent measurements is controlled by measTime.

8.2 Wake-up & Sleep Mode

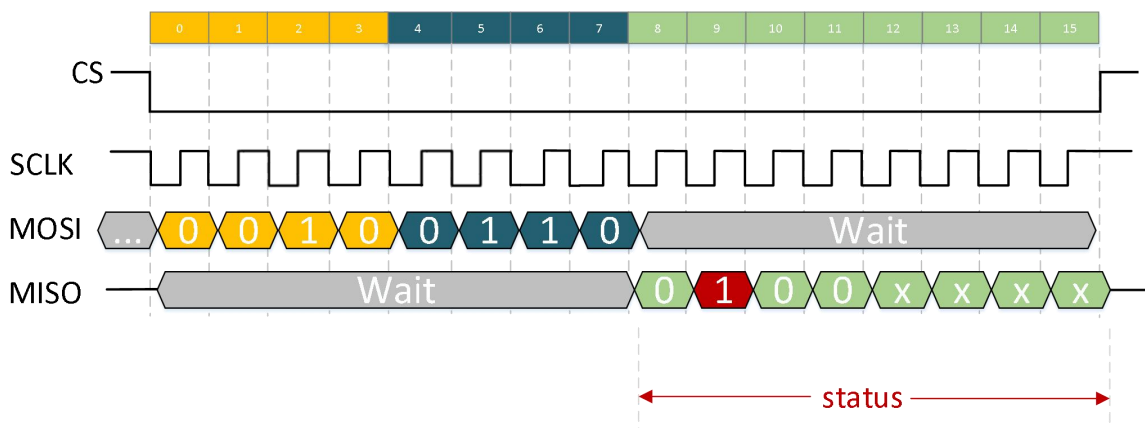

Figure 8-3. Wake-up & Sleep Mode SPI Communication Diagram

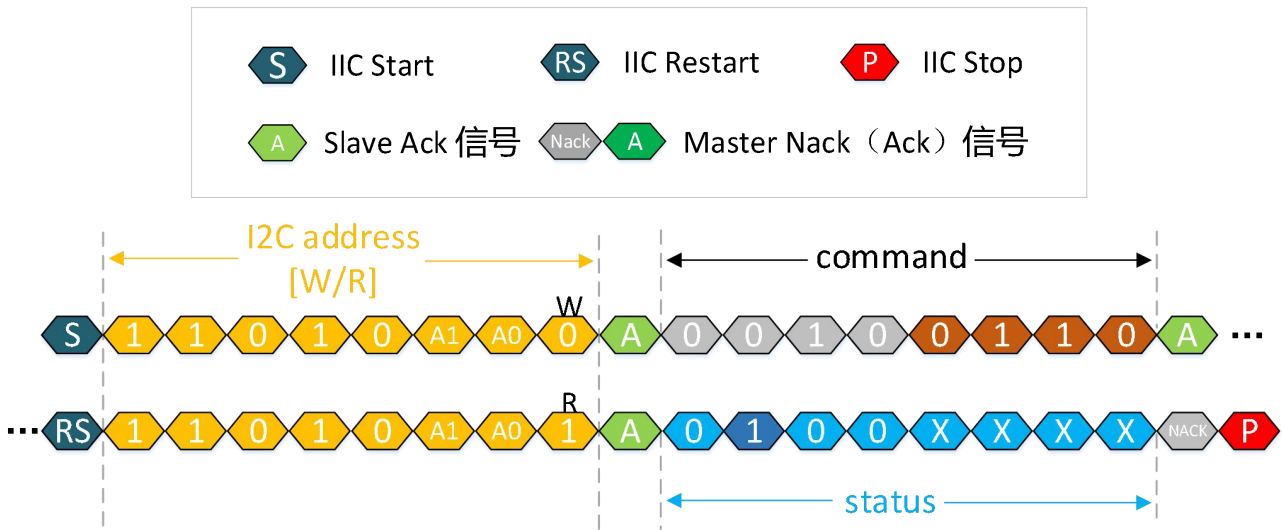

Figure 8-4. Wake-up & Sleep Mode I2C Communication Diagram

After the host sends a wake-up & sleep mode command to the chip, the chip is in a low-power measurement mode that measures the measurement item (BA) at a certain frequency until the host sends an idle mode command to the chip.

When the chip in wake-up & sleep mode, the chip INT pin is pulled high when the angle detected by the chip exceeds the set value in the threshold register. After the host reads the measurement data back once through the Data Read Frame, the INT pin is pulled low, otherwise it remains high. The chip INT pin will not actively pull down, that is, at a certain moment the angle value detected by the chip, beyond the set threshold, after the INT pin is pulled high, if the next moment, the angle value detected by the chip is lower than the set threshold again, but the host does not read back the measurement data, the INT pin will not actively pull low.

8.3 Single Conversion Mode

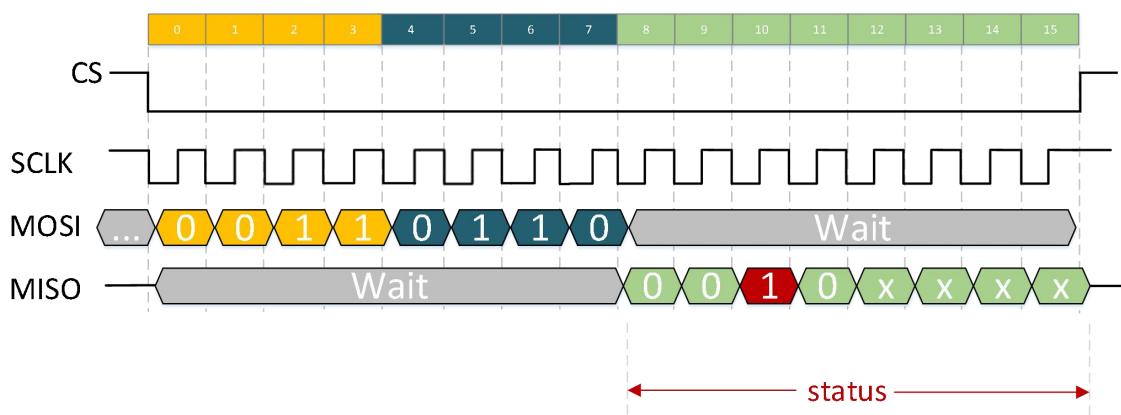

Figure 8-5. Single Conversion Mode SPI Communication Diagram

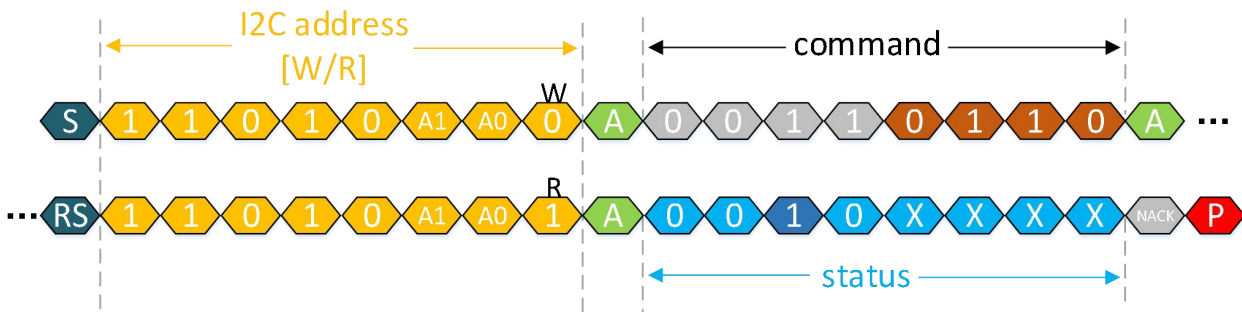
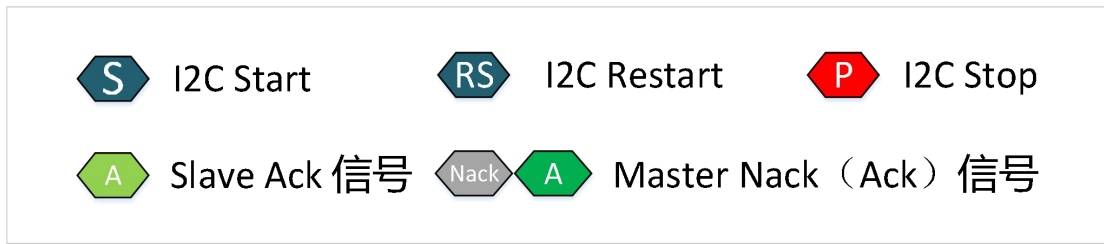

Figure 8-6. I2C Communication Diagram in Single Conversion Mode

After the host sends a single conversion mode command to the chip, the chip will measure the measurement item (BA) once, and automatically return to the idle state, the effect is equivalent to sending an idle mode command, that is, the chip receives a single conversion mode command, and after completing a measurement, there is no need to send an idle mode command to return to Idle mode.

8.4 Idle Mode

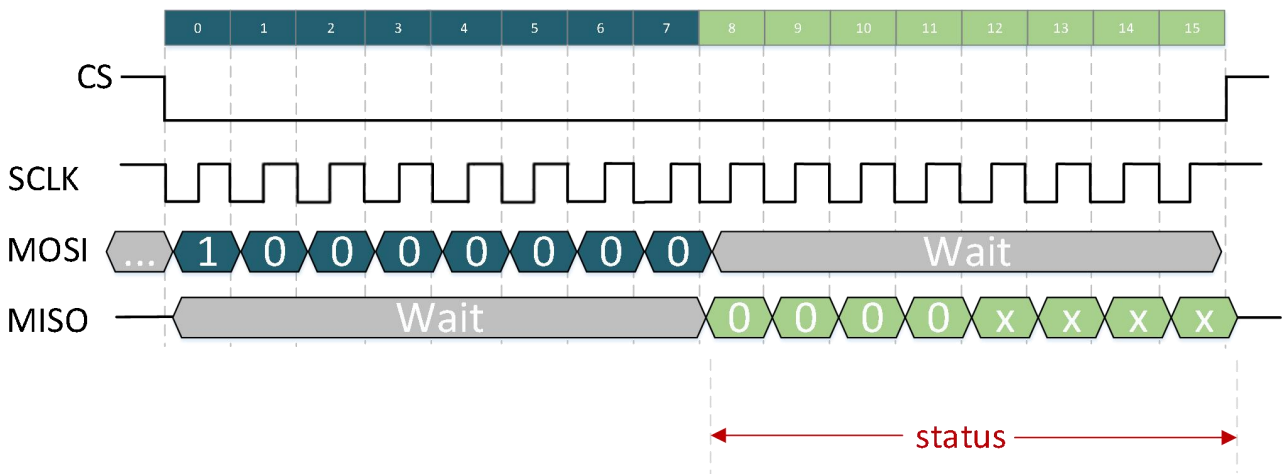

Figure 8-7. SPI Communication Diagram In Idle Mode

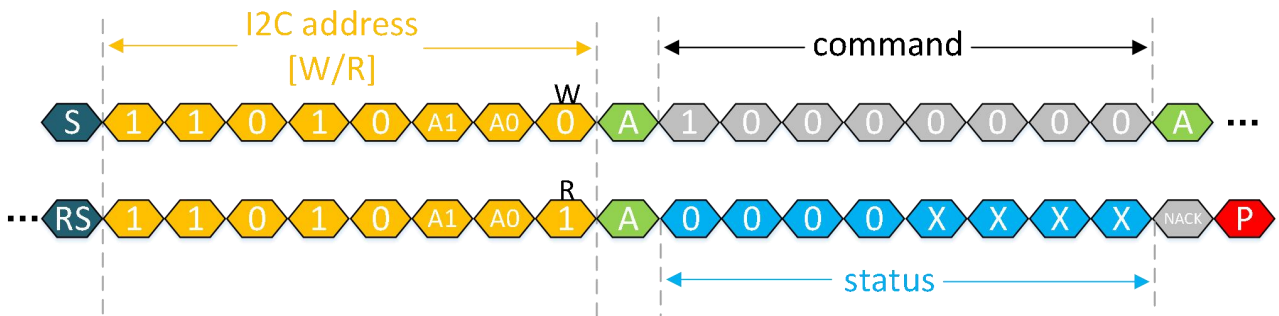
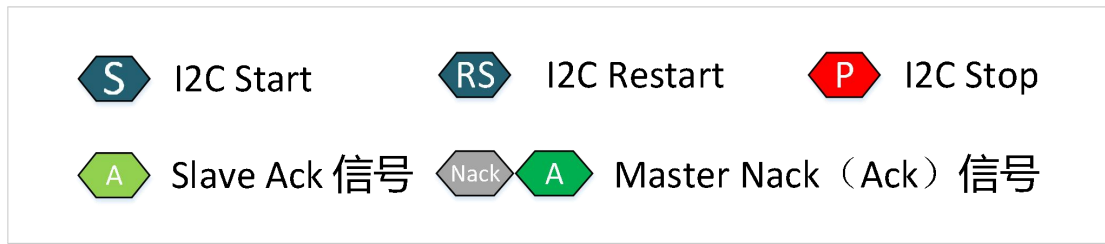

Figure 8-8. I2C Communication Diagram In Idle Mode

After the host sends an idle mode command to the chip, the chip will enter the idle state. When the chip is in continuous sensing mode or wake-up & sleep mode, the chip cannot perform operations other than the measurement data readback frame, such as reading and writing registers. If you need to perform other operations on the chip, you need to send an idle mode command first to make the chip enter an idle state. However, after sending an idle mode command, subsequent instructions cannot be executed immediately, and it is necessary to wait for the current measurement to complete before entering the idle state from the current continuous sensing mode or wake-up & sleep Mode. If additional operations are required, it is necessary to wait for a measurement time delay before proceeding.

Take the write register command as an example:

- Step 1: Send idle mode command
- Step 2: Wait for the time to complete a measurement
- Step 3: Send the write register command

Note: Idle state refers to the state that the chip is not in any measurement mode. The standby state refers to the state that the chip is in measurement mode and in intermittent measurement.

9 Reset

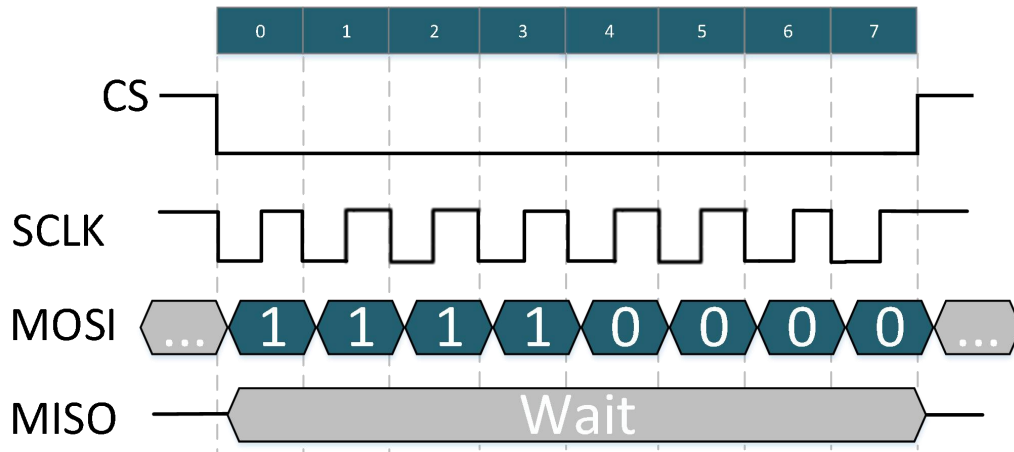

Figure 9-1. Reset SPI Communication Diagram

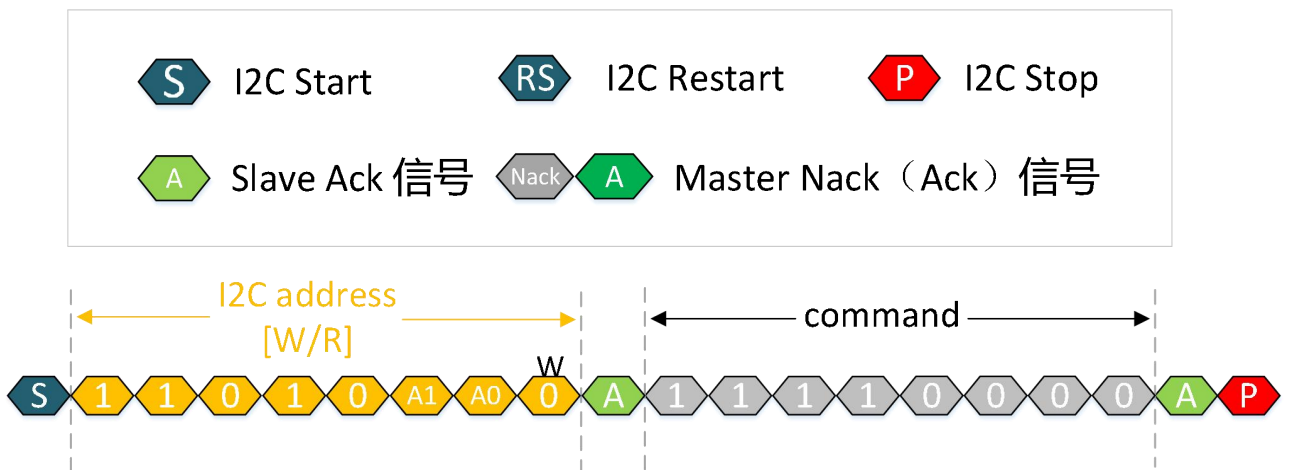

Figure 9-2. Reset I2C Communication Diagram

The internal register configuration is reset to the reset state.

If the chip is in continuous sensing mode or wake-up & sleep mode, before resetting the chip, you need to send an idle mode command to make the chip return to the idle state.

10 Operating Status Description

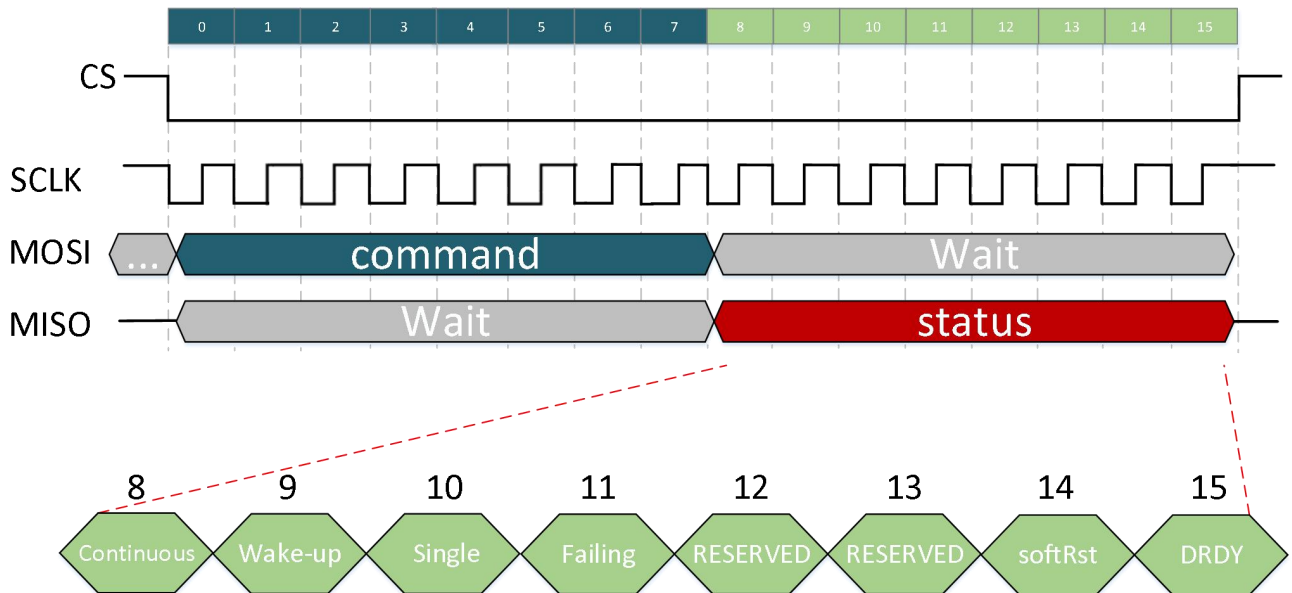

Figure 10-1. Operating Status SPI Description

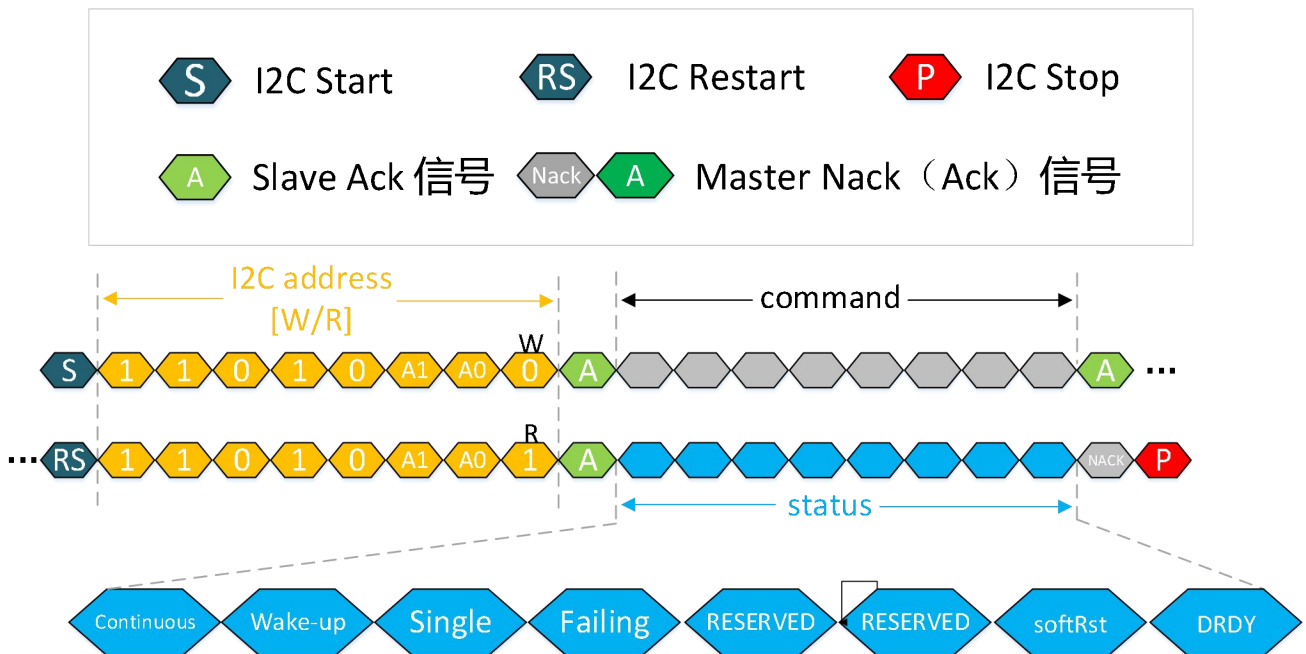

Figure 10-2. Operating Status I2C Description

In addition to resetting the chip, the chip will return to the operating status after other commands are sent;

- Continuous

When this bit is 1, it means that it is currently in continuous sensing mode. The host sends a continuous sensing mode command to the chip, and the bit in the returned status is set to 1, or when the chip is in continuous sensing mode, using the data Read Frame, the bit is also set to 1 when the measurement data is read back at one time.

- Wake-up

When this bit is 1, it means that it is currently in wake-up & sleep mode. When the host sends a wake-up & sleep mode command to the chip, the bit in the returned status is set to 1, or when the chip is in wake-up & sleep mode, using the data Read Frame, this bit is also set to 1 when the measurement data is read back at one time.

- Single

When this bit is 1, it means that it is currently in single conversion mode. When the host sends a single conversion mode command to the chip, or the host sends a high-level pulse to the chip trig pin, the command then returns the corresponding status of the bit set to 1. After completing a single measurement, the chip returns to the idle state, and if other commands are sent later, the bit is 0 in the corresponding status returned.

- Failing

Failing =1 when the currently sent command is invalid. When in any measurement state, send another measurement command again, the Failing bit will be set to 1. For example, when a single conversion command is sent while the continuous sensing mode is in progress, the Failing bit will be set to 1; At the same time, if the operation of the read and write registers is performed in continuous sensing mode, the Failing bit will also be set to 1, which represents a command error.

- RESERVED

- RESERVED

- softRst

After the host sends a Reset command to the IC, the IC will not return status immediately. Therefore, it is necessary to judge whether the reset is successful according to the status returned when any command is received for the first time after the chip is reset. This bit is set to 1 after the chip is successfully reset, and is cleared to 0 after status is returned once, that is, when the chip receives any command for the second time after reset, the bit of status is 0.

- DRDY

When the host sends Continuous Sensing mode to the chip, the bit is set to 1 after each measurement, and the bit is cleared 0 after completing a data reading. When the host sends a single conversion mode to the chip, the bit is set to 1 after the measurement is completed, and the bit is cleared to 0 after completing a data reading. When the host sends Wake-up & Sleep Mode to the chip, when the corresponding magnetic field change detected by the chip exceeds the set threshold, the bit is set to 1, and the bit clears 0 after completing a data reading.

11 Data Read Frame

After the chip completes a measurement, the data readback frame can be used to read back the chip status and all measurement data at once.

As shown in the following figure, after the host sends a data readback command to the chip, the chip returns the measurement values of all gating items to the host at one time.

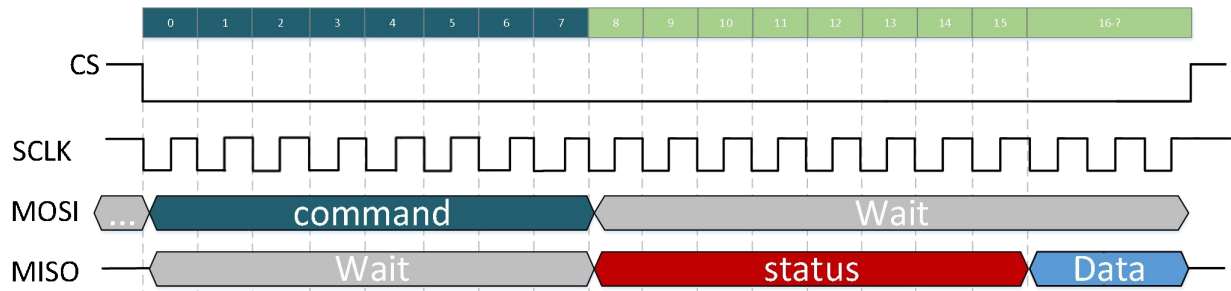

Figure 11-1. Data Read Frame SPI Communication Diagram

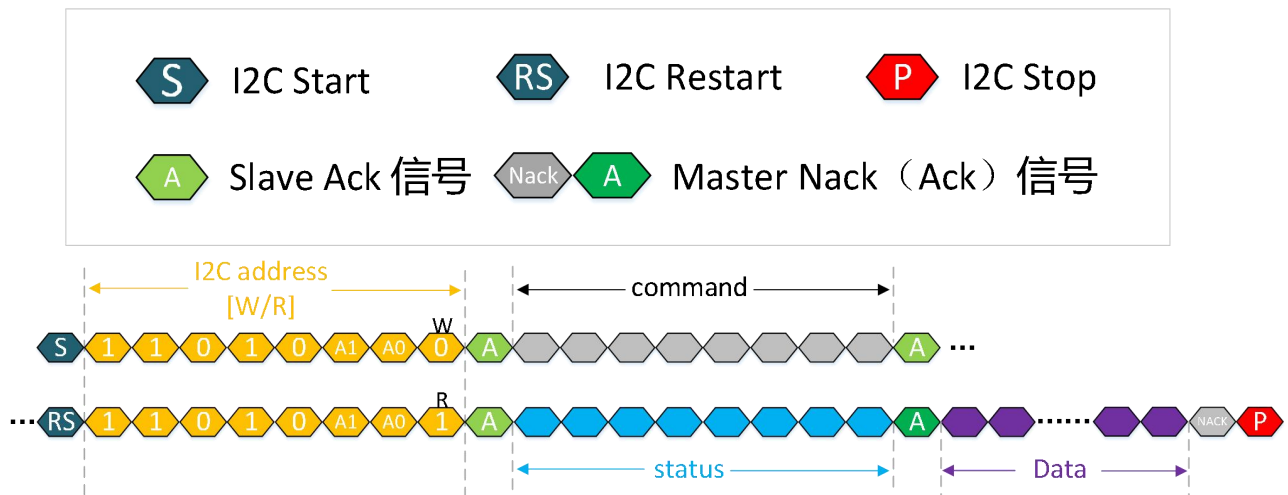

Figure 11-2. Data Read Frame I2C Communication Diagram

11.1 Read Back Method

The host sends a one-time data readback command to the chip, which can read back the AB value. B: Corresponding amount of plane magnetic flux density, A: plane angle.

The sending part is shown in the figure below, and the complete communication format is shown in Figure 11-11 and Figure 11-12.

Returns a 16-bit angle value, and the angle corresponding to each LSB is: $\frac{360^\circ}{2^{16}}$. Example: A [15:0] = 0x1000, XY

$$\text{plane magnetic field angle } \theta = \frac{A[15:0] * 360^\circ}{2^{16}} = \frac{4096 * 360^\circ}{2^{16}} = 22.5^\circ.$$

The θ value is calculated by Bx,By by the CORDIC algorithm, and the corresponding value of the magnetic flux

$$\text{density is } \frac{B[15:0] * 0.60725}{\text{Sensitivity}}$$

As shown in the figure below.

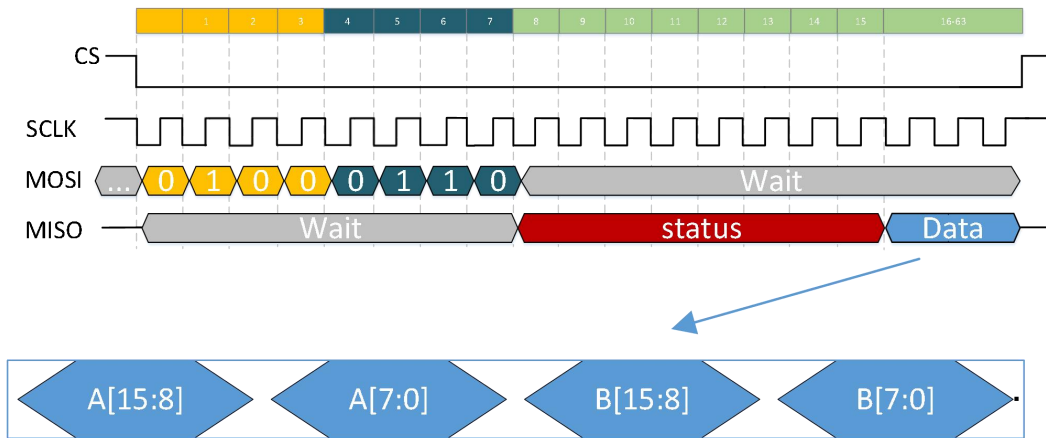

Figure 11-3. Data Readback SPI Communication Diagram

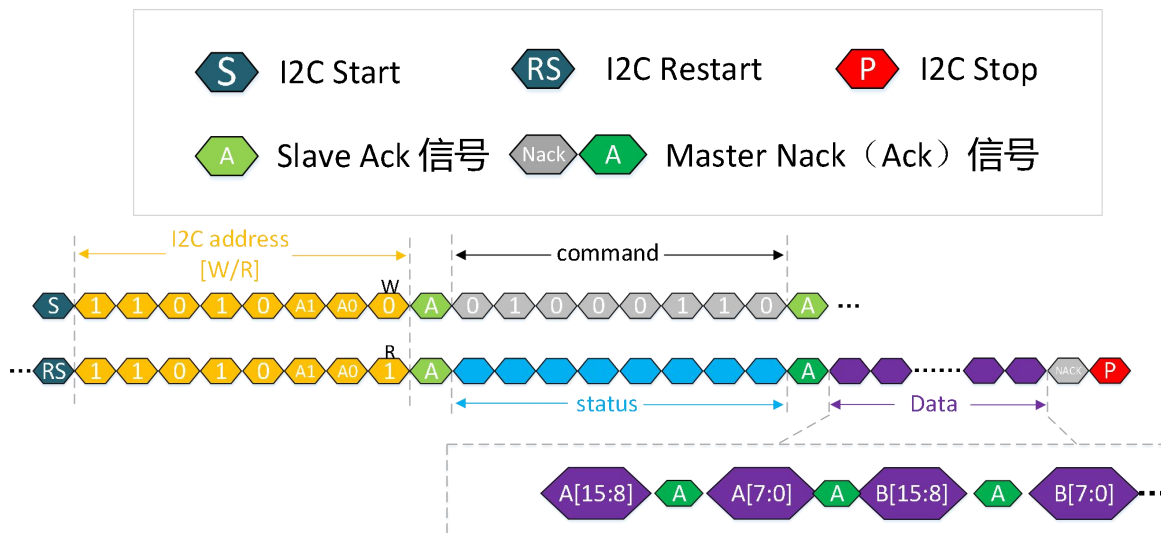

Figure 11-4. Data readback I2C Communication Diagram

12 SPI Communication Mode

Note: The following parameters are measured at room temperature 25° C and Vdd = 3.3V.

The design uses SPI mode 3: CPHA=1 (data changes at the first edge, the second edge is sampled), CPOL=1 (high level is invalid).

KTH5702 series



Low power, high accuracy 2D Hall rotary position sensor

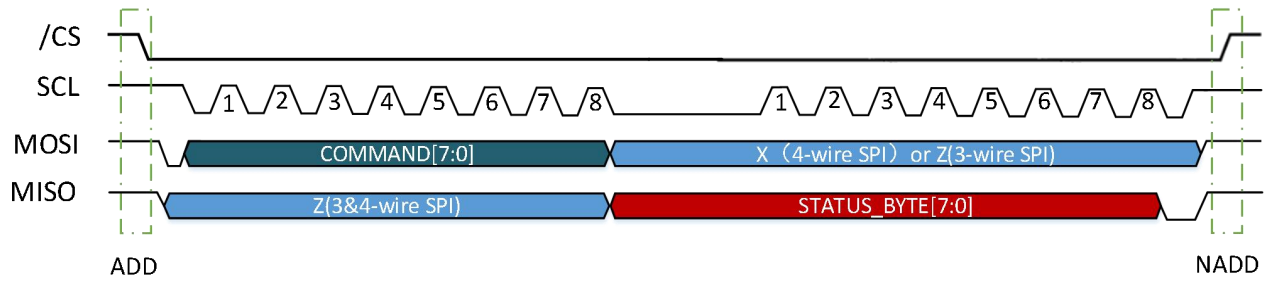

Electrical Parameters	Symbol	Min.	Max.	Unit
SPI Clock Cycle	$t_c(\text{SPC})$	200		ns
SPI Clock Cycle	$t_c(\text{SPC})$		5	MHz
CS Setup Time	$t_{su}(\text{CS})$	5		ns
CS Hold Time	$t_h(\text{CS})$	10		ns
SDI Input Setup Time	$t_{su}(\text{SI})$	5		ns
SDI Input Hold Time	$t_h(\text{SI})$	15		ns
SDO Valid Output Time	$t_v(\text{SO})$		50	ns
SDO Output Hold Time	$t_h(\text{SO})$	5		ns
SDO Output Disable Time	$t_{dis}(\text{SO})$		50	ns

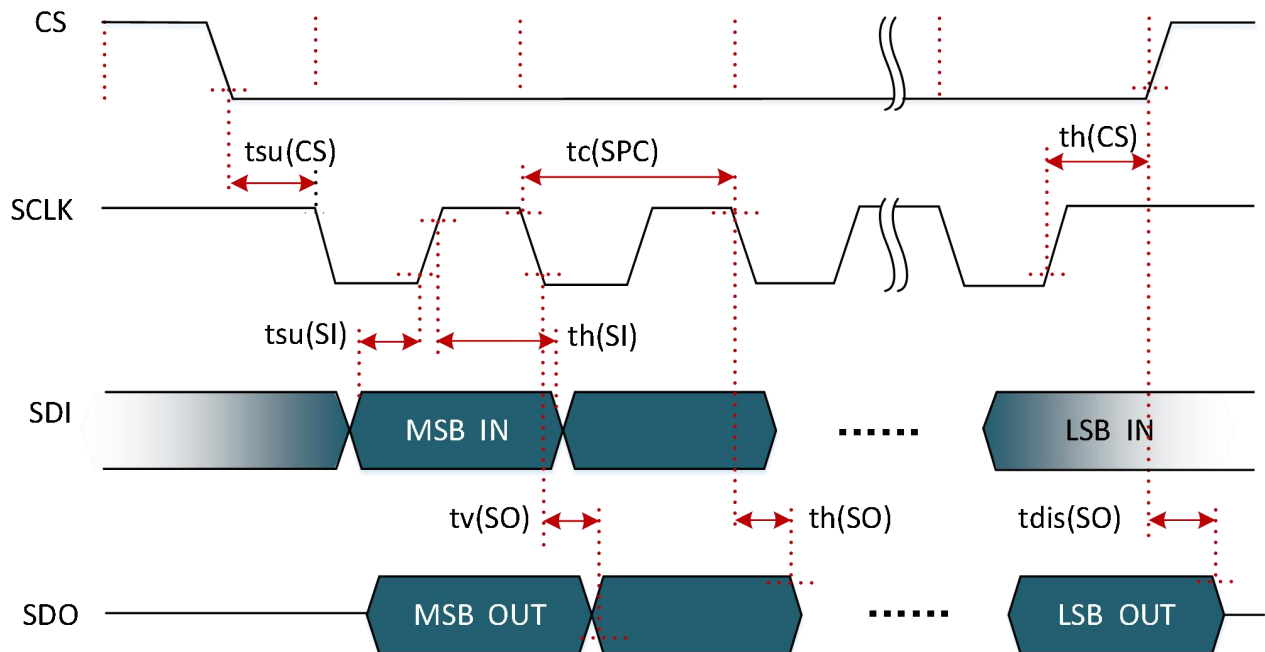

Figure 12-1 SPI Timing Diagram

13 I2C Communication Mode

Note: The following parameters are measured at room temperature 25° C and Vdd = 3.3V.

Electrical Parameters	Symbol	Standard Mode		Fast Mode		Unit
		Min.	Max.	Min.	Max.	
SCL Clock Frequency	f (SCL)		100		400	kHz
SCL Clock Low Time	tw (SCLL)	4.7		1.3		μ s
SCL Clock High Time	tw (SCLH)	4		0.6		μ s
SDA Setup Time	tsu (SDA)	250		100		ns
SDA Data Hold Time	th (SDA)		3.45		0.9	μ s
SDA and SCL Rise Time	tr (SDA) tr (SCL)		1000		300	ns
SDA and SCL Fall Time	tf (SDA) tf (SCL)		300		300	ns
START Condition Hold Time	th (ST)	4		0.6		μ s
REPEATED START Condition Setup Time	tsu (SR)	4.7		0.6		μ s
STOP Condition Setup Time	tsu (SP)	4		0.6		μ s
Bus Free Time Between STOP and START Condition	tw(SP:ST)	4.7		1.3		μ s

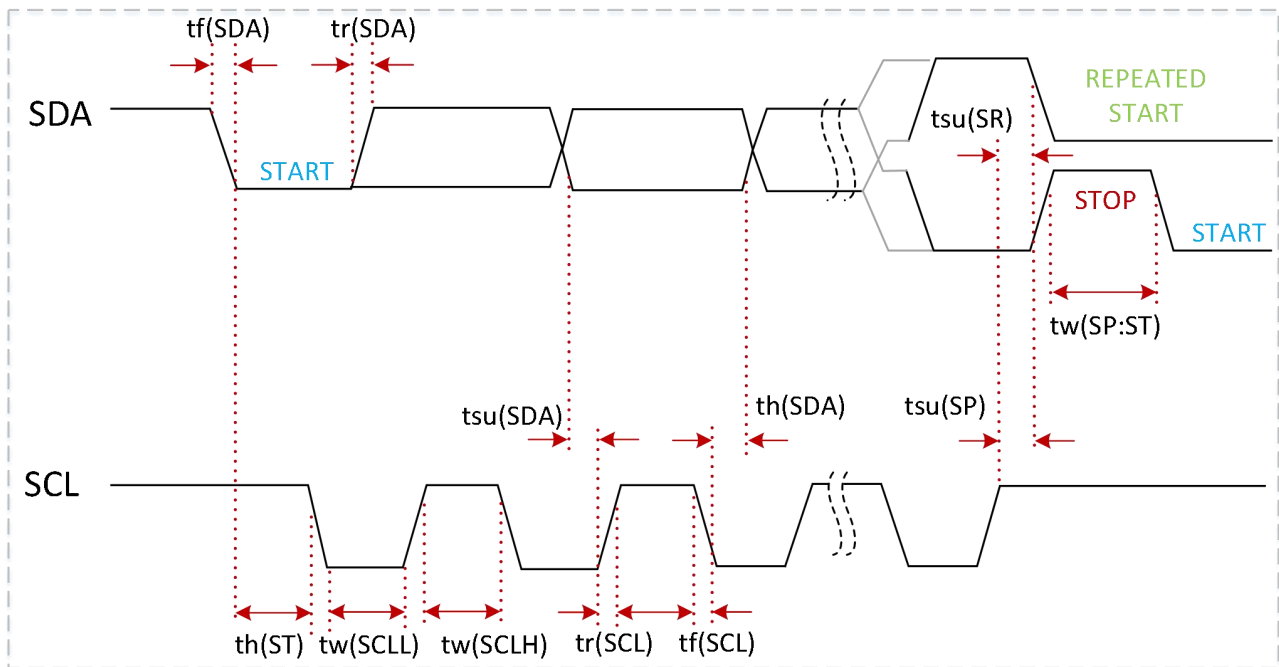

Figure 13-1 I2C Timing Diagram

14 Special Pin Description

INT: The host sends a continuous sensing mode or a single measurement command to the chip, and after the chip completes a measurement of the corresponding measurement item, the INT pin will be set to 1, and it will remain at 1 until the chip sends a read command and reads back the measurement data. After the host sends a wake-up & sleep model command to the chip, when it detects that the amount of change in the measurement item exceeds the change threshold set in the register, the INT pin is set to 1, and it remains at 1 until the chip sends a read command to read the measurement data back.

TRIG: When the host configures this pin as a single conversion mode trigger pin, if the host sends a high-level pulse to the TRIG pin, the chip makes a single measurement. When the TRIG pin is configured as a trigger pin, the pin cannot float. This pin cannot float and needs to remain low after the external triggering completes.

15 Read and Write Register Description

After the chip is powered on, internal initialization is carried out, when the power supply is stable, communication is not allowed within 4ms, and when the initialization is completed, the chip enters an idle state, allowing communication measurement.

When reading and writing registers, the register address should be shifted two bits to the left, as shown in the figure.

15.1 SPI Communication

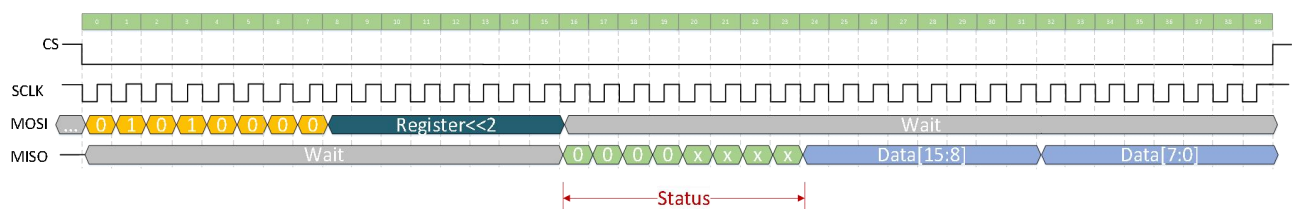

Figure 15-1. Read Register SPI Timing Diagram

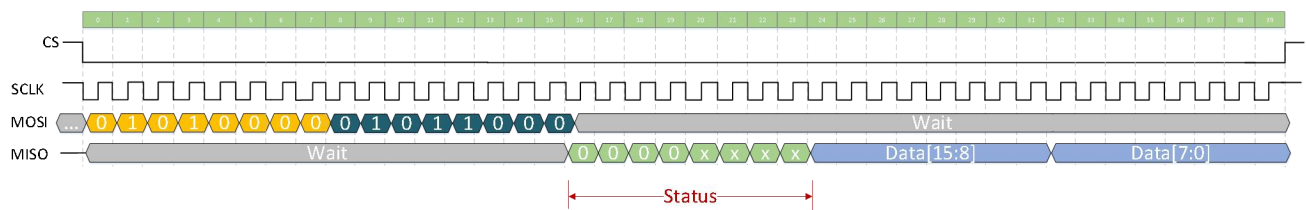

Figure 15-2. Read Register 0x16 SPI Timing Diagram

KTH5702 series



Low power, high accuracy 2D Hall rotary position sensor

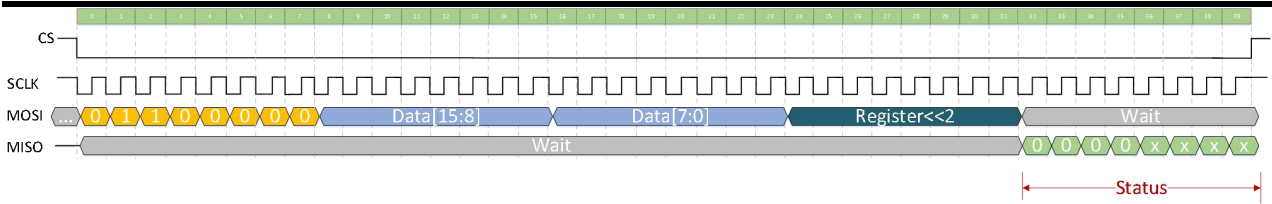

Figure 15-3. Write Register SPI Timing Diagram

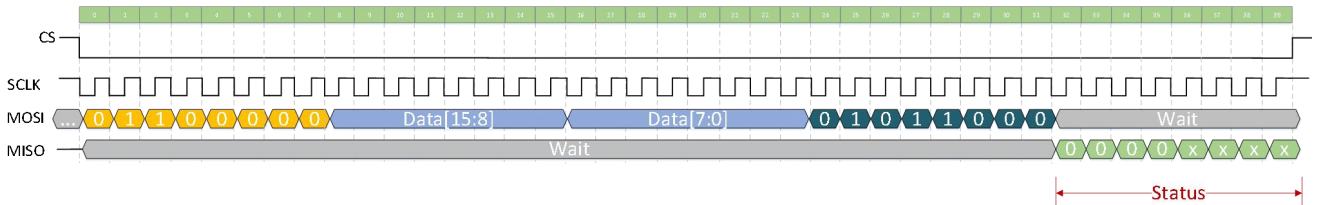

Figure 15-4. Write Register 0x16 SPI Timing Diagram

15.2 I2C Communication

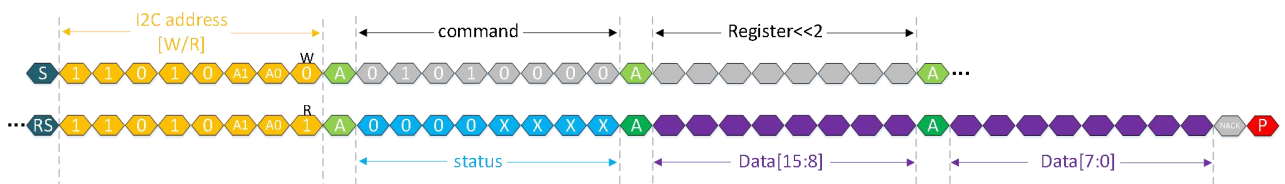
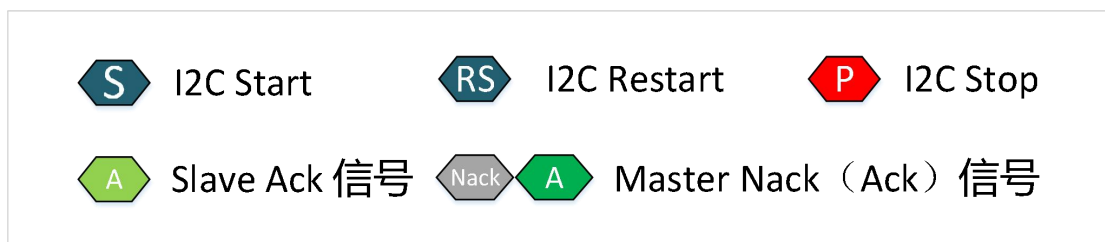

Figure 15-5. Read Register I2C Timing Diagram

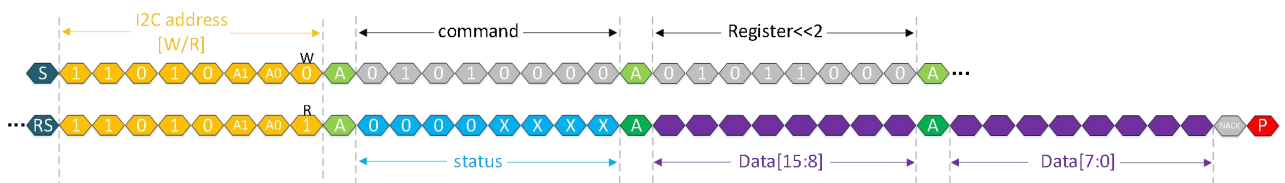

Figure 15-6. Read Register 0x16 I2C Timing Diagram

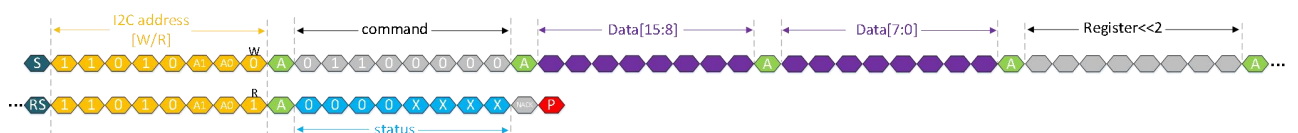

Figure 15-7. Write Register I2C Timing Diagram

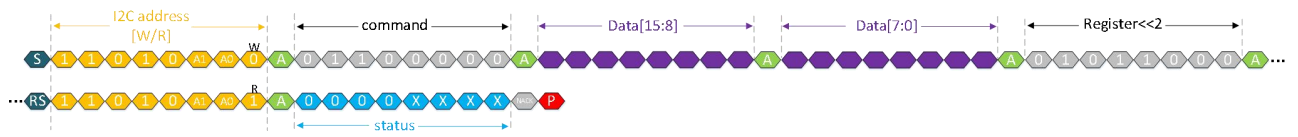

Figure 15-8. Write Register 0x16 I2C Timing Diagram

16 Register Map Description

	15	14	13	12	11	10	9	8	7	6	5	4	3	2	1	0
0x06									Continuous	Wake-up	Single	Failing	RESERVED	softRst	DRDY	
0x07	RESERVED															
0x08	RESERVED															
0x09	RESERVED															
0x0A																add[5:0]
0x0B	RESERVED															
0x0D	RESERVED															
0x14 ~0x18	RESERVED															
0x19	wxyTh[15:0]															
0x1A	RESERVED															
0x1B	RESERVED															
0x1C	RESERVED					magnOsr			RESERVED					digCtrl		
0x1D	RESERVED					measSel					measTime					
0x1E	RESERVED	zero[15:1]														
0x1F	RESERVED															

Colour legend for the Bitmap

	Status		Wake Up Sleep Mode
---	--------	---	-----------------------

KTH5702 series



Low power, high accuracy 2D Hall rotary position sensor

0x06

15	14	13	12	11	10	9	8	7	6	5	4	3	2	1	0
----	----	----	----	----	----	---	---	---	---	---	---	---	---	---	---

									Continu uous	Wake- up	Single	Failing	RESERVED	softRst	DRDY
--	--	--	--	--	--	--	--	--	-----------------	-------------	--------	---------	----------	---------	------

Status register, when the host sends a command to KTH5702 according to the communication protocol, if the sent command requires KTH5702 to answer, the chip will return the current chip status in the first byte, and this status value corresponds to the flag bits stored in the 0x06 register.

Bit Name	Bit	R/W	Description
DRDY	0	R	When the host sends Continuous Sensing mode to the chip, the bit is set to 1 after each measurement, and the bit is cleared 0 after completing a data reading. When the host sends a single conversion mode to the chip, the bit is set to 1 after the measurement is completed, and the bit is cleared to 0 after completing a data reading. When the host sends Wake-up & Sleep Mode to the chip, when the corresponding magnetic field change detected by the chip exceeds the set threshold, the bit is set to 1, and the bit clears 0 after completing a data reading.
softRst	1	R	After the host sends a Reset command to the IC, the IC will not return status immediately. Therefore, it is necessary to judge whether the reset is successful according to the status returned when any command is received for the first time after the chip is reset. This bit is set to 1 after the chip is successfully reset, and is cleared to 0 after status is returned once, that is, when the chip receives any command for the second time after reset, the bit of status is 0.
RESERVED	3:2	R	
Failing	4	R	Failing = 1 when the currently sent command is invalid. When other measurement commands are sent again during any measurement state, the Failing bit will be set to 1, for example, a single measurement command is sent at the same time in Continuous Sensing Mode, and the Failing bit will be set to 1; At the same time, if the operation of reading and writing registers is performed in Continuous Sensing Mode, the Failing bit will also be set to 1, indicating a command error.
Single	5	R	After the host sends a single measurement command (0x3x) to the chip, or the host sends a high-level pulse to the chip trig pin, the chip enters a Single Conversion Mode, and the bit is set to 1.
wake-up	6	R	After the host sends a Wake-up & Sleep Mode command (0x2x) to the chip, the chip enters wake-up measurement mode, and the bit is set to 1.
Continuous	7	R	After the host sends a Continuous Sensing Mode command (0x1x) to the chip, the chip enters the Continuous Sensing Mode, and the bit is set to 1.

KTH5702 series



Low power, high accuracy 2D Hall rotary position sensor

0x19h:

15	14	13	12	11	10	9	8	7	6	5	4	3	2	1	0
----	----	----	----	----	----	---	---	---	---	---	---	---	---	---	---

wxyTh															
-------	--	--	--	--	--	--	--	--	--	--	--	--	--	--	--

Bit Name	Bit	R/W	Description
wxyTh	15:0	RW	<p>When the chip detects a plane angle greater than the configured value in wxyTh, the INT pin is pulled up, and the calculation method for writing the angle in wxyTh is consistent with the calculation method for reading the chip angle output.</p> <p>For example, if the chip detects an angle greater than 45 ° in the XY plane, and the INT pin is pulled up, write the hexadecimal number corresponding to $\frac{45^\circ * 2^{16}}{360^\circ}$ in wxyTh, which is 0x2000. Regardless of whether the external angle value changes, as long as the angle between the planes detected by the chip is greater than 45 °, the INT pin will be pulled up.</p>

0x1Ch:

15	14	13	12	11	10	9	8	7	6	5	4	3	2	1	0
----	----	----	----	----	----	---	---	---	---	---	---	---	---	---	---

RESERVED				magnOsr	RESERVED				digCtrl
----------	--	--	--	---------	----------	--	--	--	---------

位名	位	R/W	说明										
digCtrl	2:0	RW	Digital Filter Control Parameters.										
RESERVED	8:3	R											
magnOsr	10:9	RW	<p>The ADC oversampling rate measured by the chip, corresponding to two bits from low to high, respectively represent 32, 64, 128, and 256 sampling points at one time.</p> <table border="1" style="margin-left: 20px;"> <thead> <tr> <th>magnOsr</th> <th>0x03</th> <th>0x02</th> <th>0x01</th> <th>0x00</th> </tr> </thead> <tbody> <tr> <td>Number of sampling points</td> <td>256</td> <td>128</td> <td>64</td> <td>32</td> </tr> </tbody> </table> <p>The total number of points taken by the ADC = $2^{\text{magnOsr}} \times (2^{\text{digCtrl}} + 2)$ The time at which the chip made an angle measurement = (the number of</p>	magnOsr	0x03	0x02	0x01	0x00	Number of sampling points	256	128	64	32
magnOsr	0x03	0x02	0x01	0x00									
Number of sampling points	256	128	64	32									

KTH5702 series



Low power, high accuracy 2D Hall rotary position sensor

			ADC points + 69) * 2 μ s
RESERVED	15:11	R	

0x1Dh:

15	14	13	12	11	10	9	8	7	6	5	4	3	2	1	0
RESERVED						measSel			measTime						

Bit Name	Bit	R/W	Description
measTime	5:0	RW	During Continuous Sensing Mode and Wake-up & Sleep Mode, control the intermittent waiting time between each measurement (standby state duration). The value set in measTime controls the number of delays, with one lsb corresponding to a waiting delay of 20 ms. The value in measTime corresponds to the decimal setting and how many times the delay is performed. If measTime = 0x05, the waiting time between the two measurements of the chip is 5 times with a delay of 20ms, 5*20ms=100ms.
measSel	9:6	RW	Measure the select communication signal , when the host sends three measurement mode commands to the chip without gating, can be gated by measSel corresponding to the BA bit, i.e. measSel[3:0] = 0x0C, then gate BA two measurement channels.
RESERVED	15:10	R	

0x1Eh:

15	14	13	12	11	10	9	8	7	6	5	4	3	2	1	0
RESERVED	Zero[15:1]														

Bit Name	Bit	R/W	Description
Zero[15:1]	14:0	RW	Set the first 15 bits of the zero value of the angle output. Reverse the value that needs to be set to zero plus 1, and write the first 15 bits into the zero register. For example, if you need to set the angle 0x01AA to zero, the value of zero is 0x7F2B.
RESERVED	15	R	

KTH5702 series



Low power, high accuracy 2D Hall rotary position sensor

17 Reference Circuit

Note: In order to ensure the stability of communication, be sure to use a combination capacitor of 0.1 μ f and 10 μ f, and the capacitor is as close as possible to the chip VDD. The A0 and A1 pins are grounded when not in use.

17.1 SPI

- R1 = R2 = 4.7k ohm
- C1 = C3 = 0.1 μ F
- C2 = C4 = 10 μ F

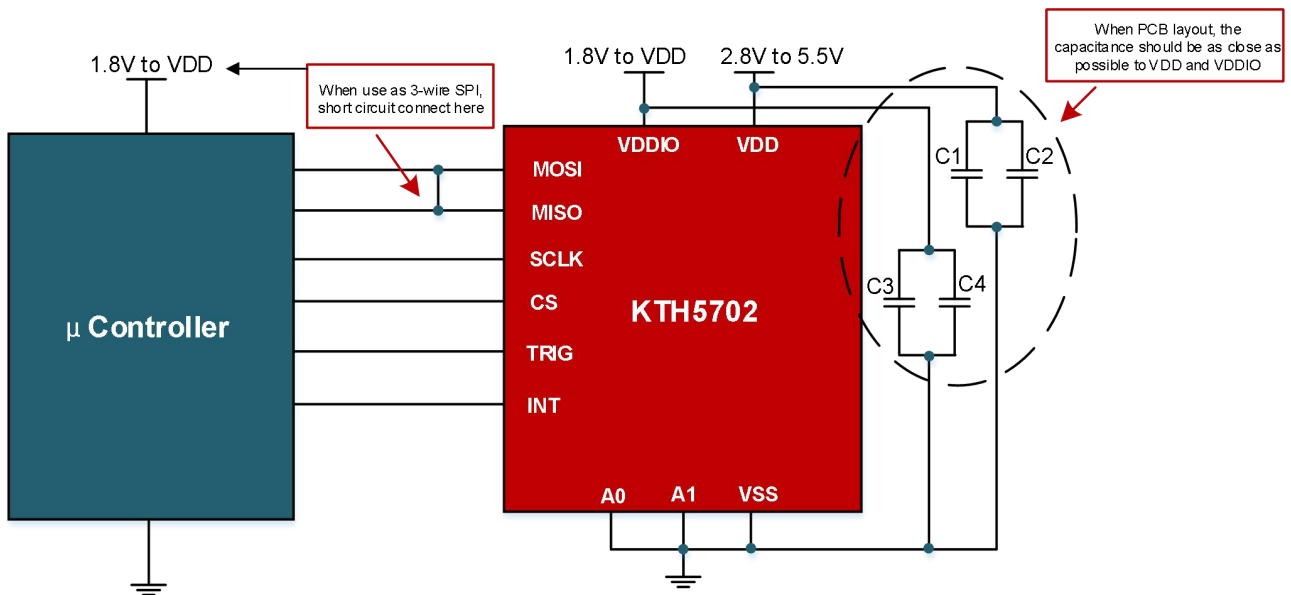

KTH5702 series



Low power, high accuracy 2D Hall rotary position sensor

17.2 I2C

A1	A0	I2C Address
VSS	VSS	1101000R / W
VSS	VDD	1101001R / W
VDD	VSS	1101010R / W
VDD	VDD	1101011R / W

R1 = R2 = 4.7k ohm
 C1 = C3 = 0.1 μ F
 C2 = C4 = 10 μ F

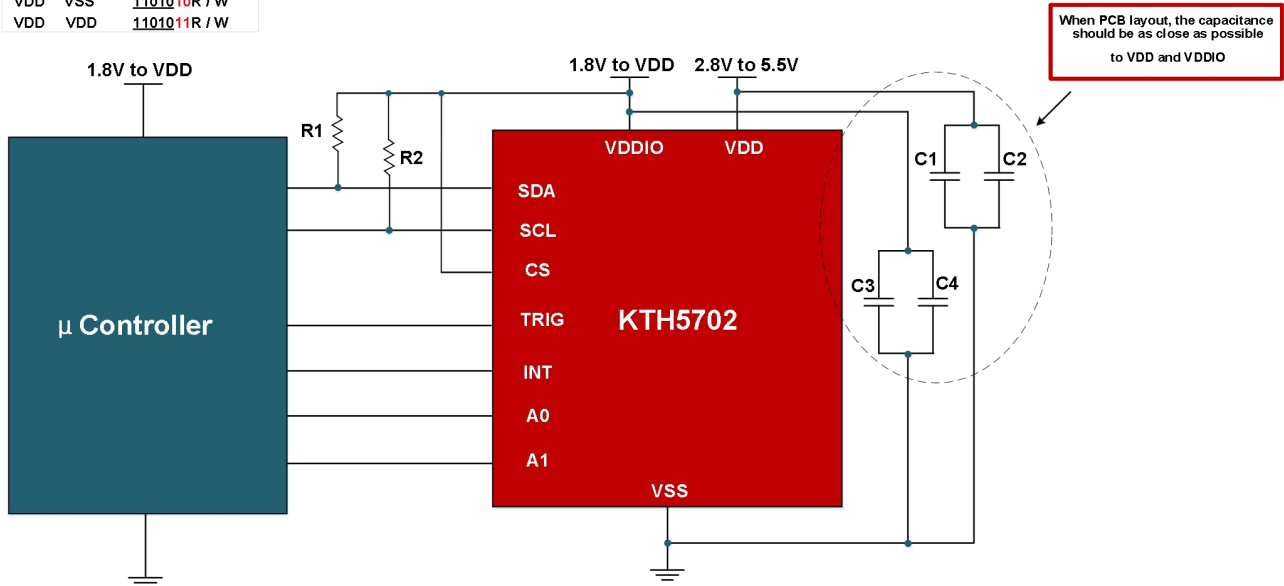

18 QFN_16PIN Package Dimensions

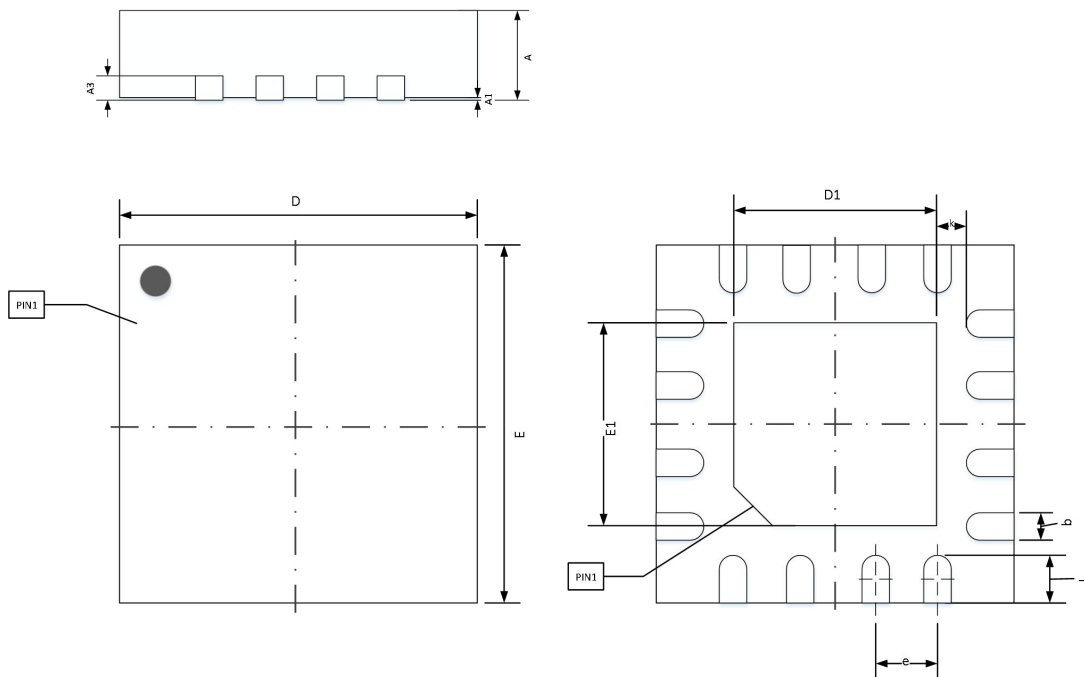

KTH5702 series



Low power, high accuracy 2D Hall rotary position sensor

Figure 18-1. QFN_16PIN Package Dimensions

Symbol	Unit: mm	
	Min.	Max.
A	0.700	0.800
A1	0.000	0.050
A3	0.203REF.	
D	2.900	3.100
E	2.900	3.100
D1	1.350	1.550
E1	1.350	1.550
k	0.375REF.	
b	0.200	0.300
e	0.500BSC.	
l	0.300	0.500

19 Order Information

Part Numbers	Package	Temperature	Application	Number of Pins
KTH5702AQ2QNS	QFN3x3-16L	-40°C ~ +85°C	Industrial Grade	16
KTH5702AQ3QNS	QFN3x3-16L	-40°C ~ +85°C	Consumer Grade	16

KTH5702 series



Low power, high accuracy 2D Hall rotary position sensor

20 Strap and Reel Information

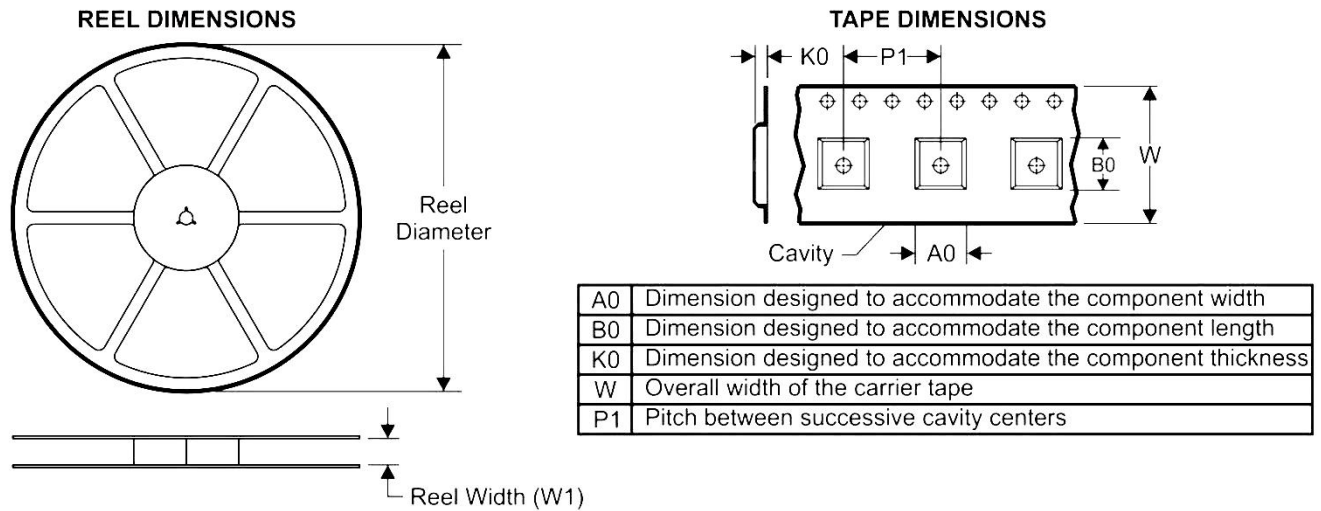

QUADRANT ASSIGNMENTS FOR PIN 1 ORIENTATION IN TAPE

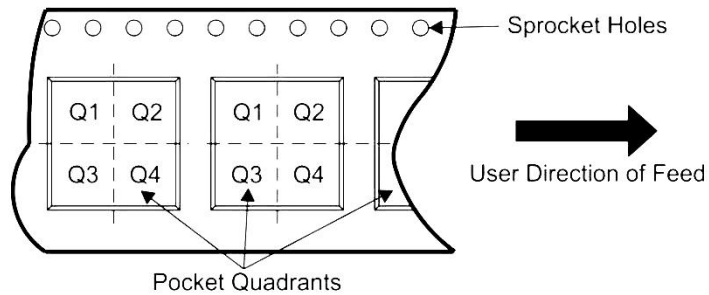

Package Type	Pins	SPQ	Reel Diameter	Reel Inside Width	A0 (mm)	B0 (mm)	K0 (mm)	P1 (mm)	W (mm)	Pin1 Direction
QFN3*3-16L	16	5000	330	12.4	3.35	3.35	1.13	8.00	12.00	Q1