

# KTH7823

***16-bit Programmable non-contact  
Hall magnetic encoders  
with ABZ and PWM outputs***

Technical Support  
support@conntek.com.cn  
+86(0)755-86006609

# Table of Contents

<b>1 Product Factsheet</b> .....	<b>1</b>
<b>2 Overview</b> .....	<b>3</b>
<b>2.1 System Architecture</b> .....	3
<b>2.2 Recommended Application Circuit</b> .....	5
<b>2.3 Pin Definitions</b> .....	6
<b>2.4 16-bit Binary Encoding of Angles</b> .....	8
<b>2.5 Product model number composition</b> .....	8
<b>2.6 Key Parameters</b> .....	9
<b>2.7 External Magnet Parameters</b> .....	10
<b>2.8 Register Configuration</b> .....	11
<b>3 SPI</b> .....	<b>12</b>
<b>3.1 SPI timing</b> .....	12
<b>3.2 Reading Registers via SPI</b> .....	15
<b>3.3 Register Writing via SPI</b> .....	15
<b>3.4 Read Absolute Angle via SPI</b> .....	16
<b>3.5 Disabling Register Configuration Functionality</b> .....	18
<b>3.6 Read Angle with CRC checksum</b> .....	19
<b>4 Angle Reading via SSI</b> .....	<b>21</b>
<b>5 ABZ Output</b> .....	<b>23</b>
<b>5.1 ABZ Output Resolution</b> .....	24
<b>5.2 ABZ Output Frequency Setting</b> .....	24
<b>5.3 Zero Index Signal Z</b> .....	25
<b>5.4 ABZ Hysteresis</b> .....	25
<b>6 PWM Absolute Position Output</b> .....	<b>26</b>
<b>7 System Operation Settings</b> .....	<b>27</b>
<b>7.1 Rotation Direction</b> .....	27
<b>7.2 Zero Point Setting</b> .....	27
<b>7.3 Threshold Detection Settings</b> .....	27
<b>7.4 Sensor Horizontal Position Calibration</b> .....	28
<b>8 Packaging</b> .....	<b>32</b>
<b>9 Tape and Reel Information</b> .....	<b>33</b>
<b>10 Soldering Temperature Profile</b> .....	<b>35</b>
<b>11 Model Selection Guide</b> .....	<b>35</b>

# 1 Product Factsheet

## Features

- 16-bit resolution absolute angle output
- High precision ( $< 0.7^\circ$  accuracy error)
- Suitable for on-axis and off-axis non-contact scenarios
- Ultra-low latency (1  $\mu$ s data updates)
- SPI communication: angle reading, register read / write
- SSI communication: angle reading
- Programmable 4-4096 steps / turn ABZ output
- PWM 14-bit angle output
- Built-in programmable memory (MTP)
- Magnetic field strength diagnosis / alarm
- Operating voltage options: 3.3V or 5V
- Operating temperature range:  $-40^\circ\text{C}$  to  $105^\circ\text{C}$
- QFN-16L package:  $3\text{mm} \times 3\text{mm}$  and SOP-8  $4.9\text{mm} \times 6\text{mm}$

## Presentation

The KTH7823 stands as a pinnacle of precision in the realm of absolute angle sensor chips. With an astonishing 16-bit resolution, it unfurls a tapestry of angle measurements with unparalleled accuracy, deftly adapting to a multitude of magnetic field scenarios. This prowess positions it as the harbinger of precision in the sprawling landscape of angle measurement and control across an extensive spectrum of applications.

At its core, the KTH7823 embodies versatility. It effortlessly accommodates a programmable 4096-step ABZ pulse output, opening the doors to the realm of high-resolution positioning. Simultaneously, its 4-wire SPI output establishes a swift and efficient channel for seamless device communication and data exchange. However, it doesn't stop there. The KTH7823 goes above and beyond, seamlessly incorporating the Synchronous Serial Interface (SSI) for angle reading. This additional communication layer extends a hand of compatibility to a diverse array

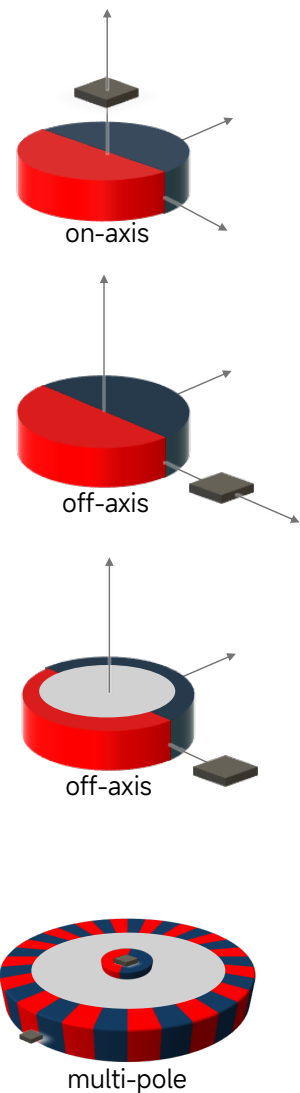

## Typical Applications

- Absolute position sensor
- Brushless DC motor
- Off-axis angle measurement
- Elevators
- Barrier gates

of systems.

But precision is not merely about numbers; it's also about control. The KTH7823 steps up to the challenge with a 14-bit PWM (Pulse Width Modulation) angle output. This finely crafted feature allows for meticulous control and the finest adjustments to angles, ensuring that precision isn't just a goal but a guarantee.

Furthermore, the KTH7823 unveils its adaptability in the form of programmable magnetic field strength detection. This ingenious addition empowers real-time monitoring and adjustments based on predefined thresholds. It's akin to having an onboard magnet connoisseur, ensuring that the optimal magnet and installation configurations are chosen with the utmost finesse.

To top it all off, the KTH7823 seamlessly integrates Memory-Programmable Technology (MPT). Within its digital memory vault, it safeguards critical configuration parameters such as zero angle position, ABZ encoder settings, and magnetic field detection thresholds. This treasure trove of data not only enhances precision but also caters to the dynamic needs of a wide array of applications.

In essence, the KTH7823 is more than just a sensor chip; it's a testament to precision engineering, a guardian of data, and a pioneer in the realm of absolute angle measurement and control. Its versatility, accuracy, and adaptability make it the ideal choice for those seeking to push the boundaries of what's possible in their applications.

## 2 Overview

### 2.1 System Architecture

Figure 1: Top diagram

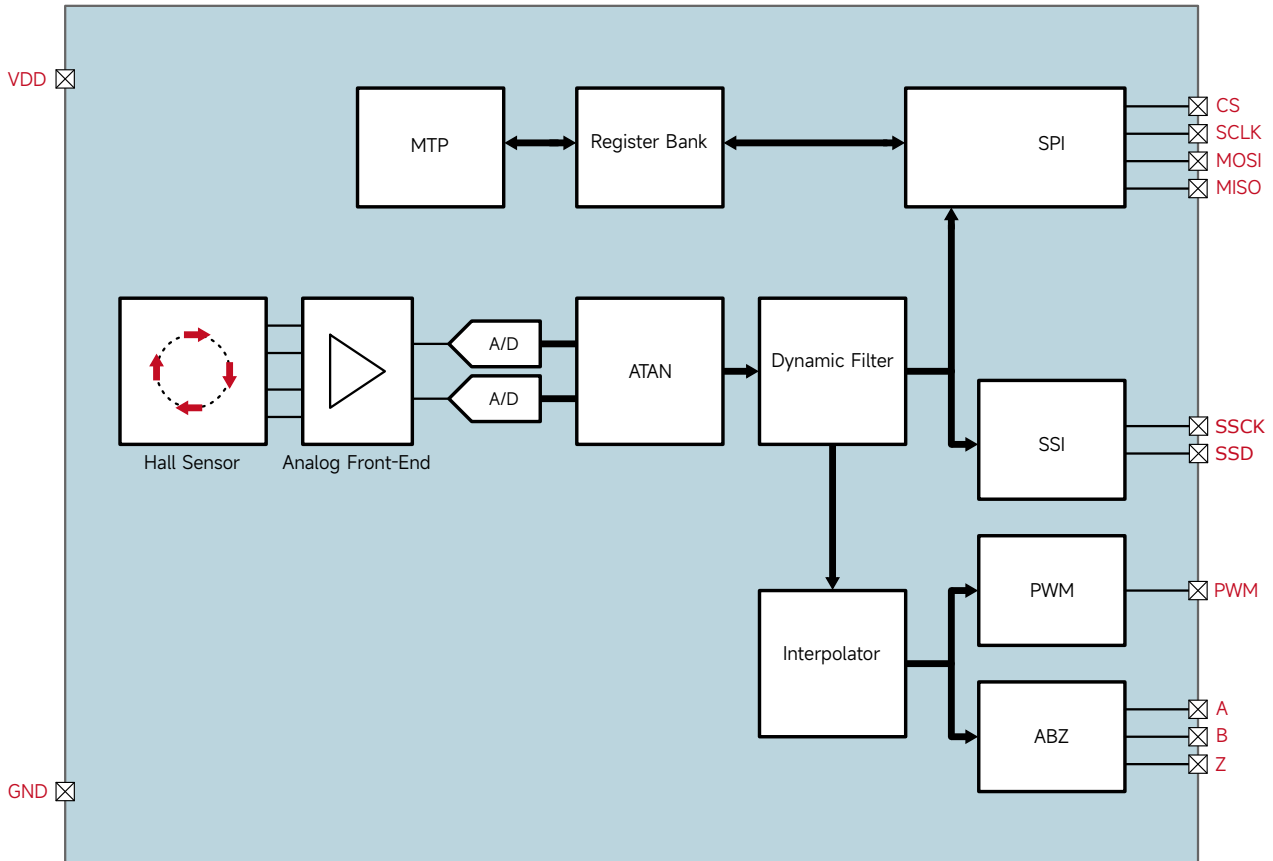

The KTH7823 is a Hall angle encoder that integrates Hall devices, analog-to-digital converters (ADCs), and various modules to precisely measure angles and output corresponding digital signals.

The encoder's Hall devices generate voltage signals, which are then converted into two orthogonal digital signals through ADCs. These signals are further processed through an ATAN module, resulting in a 16-bit digital angle representation. The digital angle undergoes zero-point calibration, rotation direction configuration, and filtering.

The output interface of the encoder allows direct communication of the filtered angle values through SPI and SSI interfaces, enabling users to read them using MCUs or other circuits. Additionally, the angle can be expressed through PWM modulation, where the duty cycle reflects the magnitude of the angle.

To enhance the refresh rate, the filtered angle can be processed through an interpolator and then output to an ABZ angle encoding module, which converts the angle into the required encoding signals.

Furthermore, various operational parameters of the system are stored in a programmable multiple-write storage (MTP), which can be modified through SPI commands to meet the requirements of different applications.

## 2.2 Recommended Application Circuit

Figure 2: Recommended Application Circuit

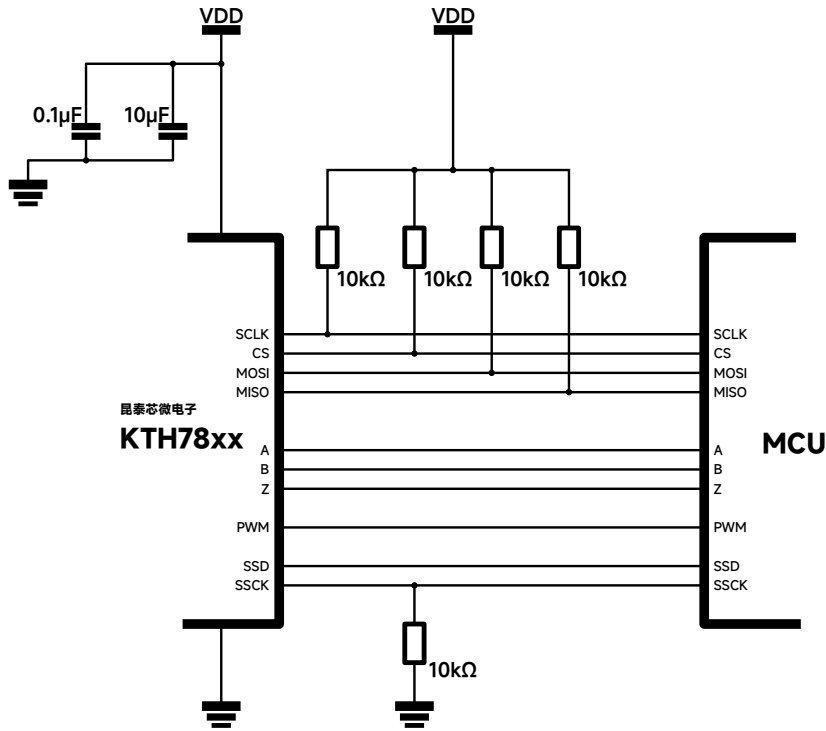

Please note that the pull-up and pull-down resistors depicted in the diagram should be kept in place even when the interface is not actively utilized.

## 2.3 Pin Definitions

Figure 3: QFN-16L 3mmx3mm

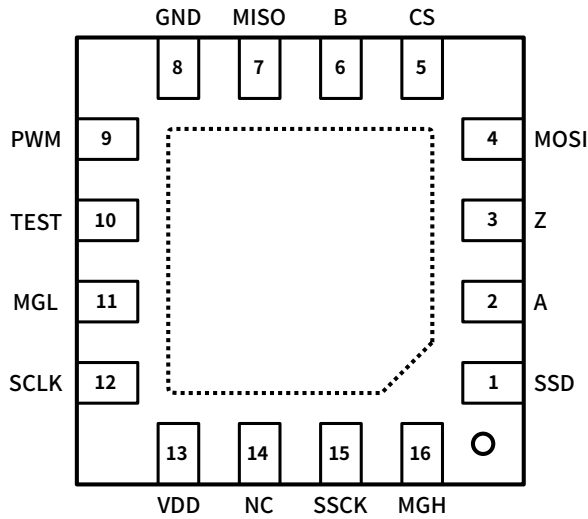
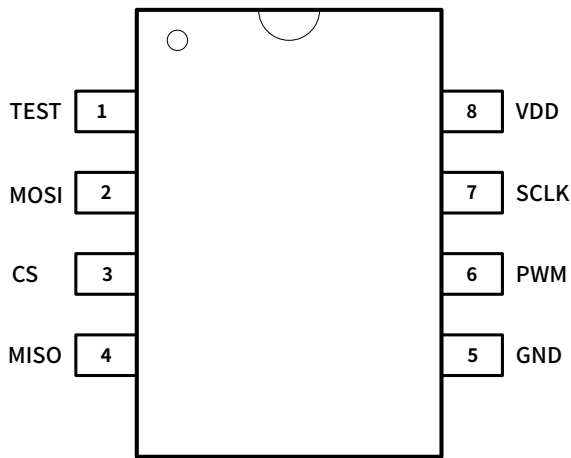

Table 1: Pin Functions

N.	Name	Function
1	SSD	SSI Data Output
2	A	One of the ABZ incremental output signals
3	Z	One of the ABZ incremental output signals
4	MOSI	SPI Master Data Output (pull-up to VDD if not used)
5	CS	SPI Chip Select (pull-up to VDD if not used)
6	B	One of the ABZ incremental coding signals
7	MISO	SPI Slave Data Output
8	GND	Ground
9	PWM	Pulse Width Modulation
10	TEST	Factory Testing (pull-down to GND)
11	MGL	Low Magnetic Field Strength
12	SCLK	SPI Clock (pull-up to VDD if not used)
13	VDD	Power Supply Input
14	NC	Not Connected
15	SSCK	SSI Data Clock Input (pull-down to GND if not used)
16	MGH	High Magnetic Field Strength



**Figure 4: SOP-8 4.9mmx6mm**



**Table 2: Pin Functions**

Num	Name	Function
1	TEST	TEST pin floating during operation
2	MOSI	SPI Master Data Output (pull-up to VDD if not used)
3	CS	SPI Chip Select (pull-up to VDD if not used)
4	MISO	SPI Slave Data Output
5	GND	Ground
6	PWM	Pulse Width Modulation
7	SCLK	SPI Clock (pull-up to VDD if not used)
6	VDD	Power Supply Input

For the KTH7823 product utilizing a QFN-16L 3x3mm package, it is mandatory to directly connect the TEST pin to the Ground (GND).

Conversely, for the KTH7823 product with a SOP-8 4.9mmx6mm package, the TEST pin should be left floating during operation.

The KTH7823 product is available in two package formats: QFN-16L and SOP-8, with pin definitions as described above. Due to the reduced pin count in the SOP-8 package, the number of output signals is correspondingly reduced.

The KTH7823 offers a wide range of pin functionalities, including ABZ-encoded incremental output, Pulse Width Modulation (PWM) output, as well as SSI and SPI communication capabilities.

## 2.4 16-bit Binary Encoding of Angles

The KTH7823 encoder represents angle values using a 16-bit binary encoding scheme. By converting angle values into a 16-bit binary form, precise representation of angles can be achieved. For instance, angle values can be expressed as integers in binary form, ranging from 0 to 65535. In general, the angles discussed in this document are represented using 16-bit binary encoding.

The relationship between the 16-bit binary value and the corresponding angle output (ranging from 0° to 360°) can be expressed mathematically as:

$$\text{Angle Output (0° to 360°)} = \frac{\text{16-bit binary value}}{2^{16}} \times 360 \quad (1)$$

Equation 1 demonstrates how the 16-bit binary value can be converted to its corresponding angle output. The division by  $2^{16}$  normalizes the binary value to a range between 0 and 1, which is then multiplied by 360 to obtain the angle output in degrees. This encoding scheme allows for accurate representation and measurement of angles using the KTH7823 encoder.

## 2.5 Product model number composition

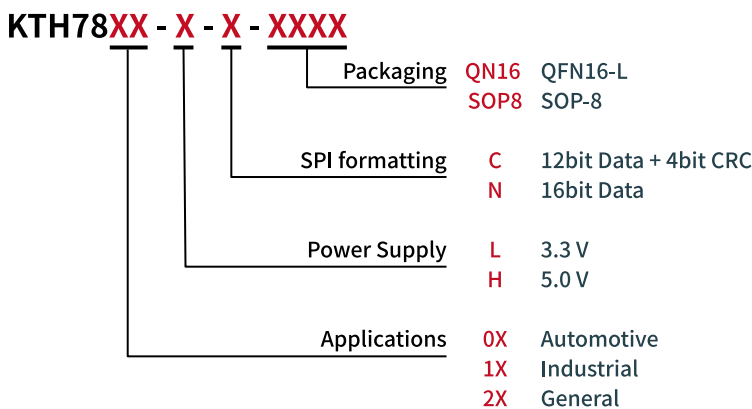

## 2.6 Key Parameters

**Table 3: Key Metrics for 3.3V Power Supply Chip**

Parameter	Minimum Value	Typical Value	Maximum Value
Operating Voltage	3.0V	3.3V	3.6V
Operating Current		11.6mA	
Startup Time		1ms	
Delay Time		1us	
Output Noise (1 $\sigma$ )		0.15°	
Temperature Drift		0.002° / °C	
Nonlinear Error		0.7°	
Rotation Speed			120,000rpm
ESD (HBM)		±5KV	

**Table 4: Key Metrics for 5V Power Supply Chip**

Parameter	Minimum Value	Typical Value	Maximum Value
Operating Voltage	4.5V	5V	5.5V
Operating Current		13.6mA	
Startup Time		1ms	
Delay Time		1us	
Output Noise (1 $\sigma$ )		0.15°	
Temperature Drift		0.002° / °C	
Nonlinear Error		0.7°	
Rotation Speed			120,000rpm
ESD (HBM)		±5KV	

## 2.7 External Magnet Parameters

**Table 5: External Magnet Parameters**

Para.	Description	Min	Typ.	Max	Unit
$D_{mag}$	Magnet Diameter, 10mm, radially magnetized pair recommended		10		mm
$T_{mag}$	Magnet Thickness, 2.5mm recommended		2.5		mm
$B_{pk}$	Magnetic Field Strength on Surface	30		150	mT
$AG$	Air Gap: Chip-Magnet Distance		1.0	3.0	mm
$RS$	Rotational Speed			120	krpm
$DISP$	Eccentricity: Magnet-Chip Center Offset			0.3	mm
$TC_{mag1}$	NdFeB Magnet's Temperature Coefficient		-0.120		%/°C
$TC_{mag2}$	SmCoMagnet's Temperature Coefficient		-0.035		%/°C

**Figure 5: Magnet-Sensor Positioning**

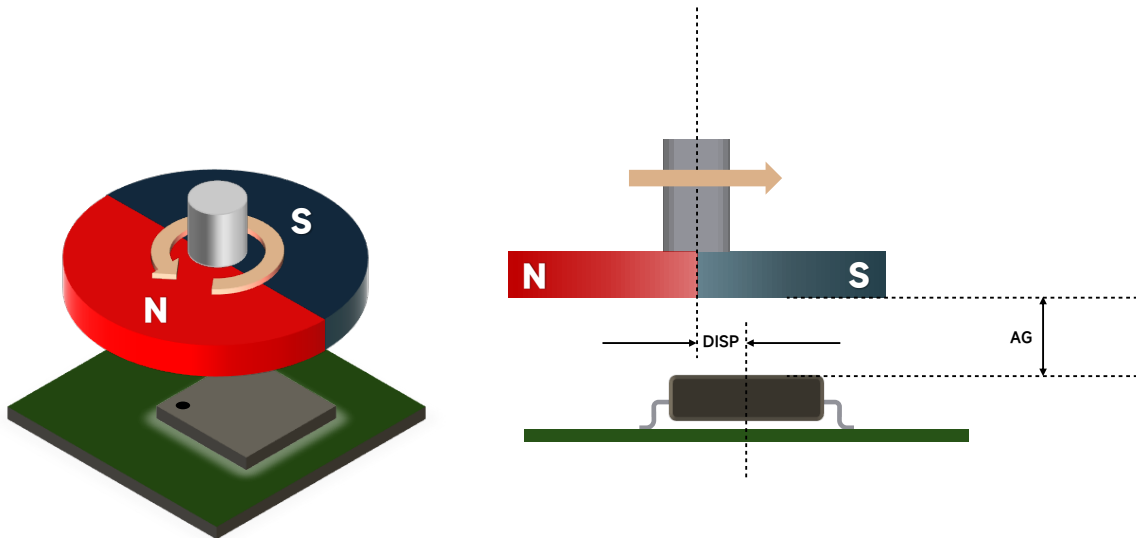

## 2.8 Register Configuration

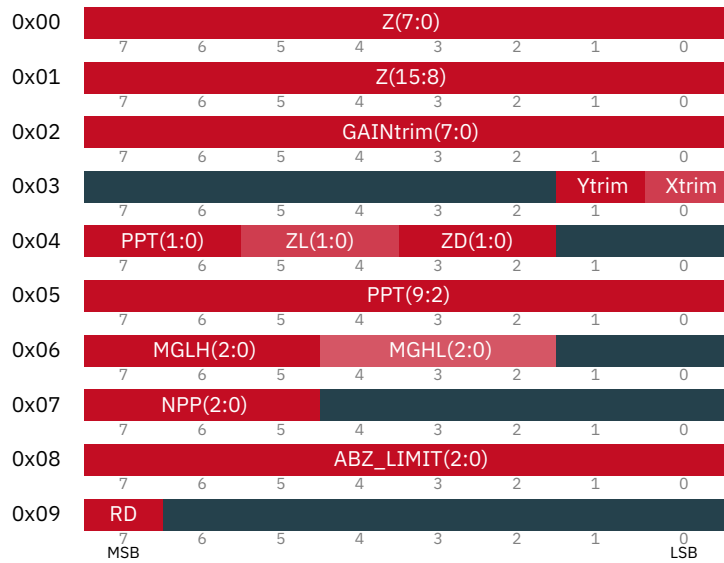

**Table 6: MTP Parameter Description**

Symbol	Default Value Decimal	Name	Description
ABZ_LIMIT(2:0)	000	ABZ output bandwidth	Chapter 5.2
GAINtrim(7:0)	00000000	Sensitivity Modulation Coefficient	Chapter 7.4
Xtrim	0	Reduce X-axis Hall Sensitivity	Chapter 7.4
Ytrim	0	Reduce Y-axis Hall Sensitivity	Chapter 7.4
MGH	0	Magnetic Field Strength Detection High Threshold Alarm Bit	Chapter 7.3
MGL	0	Magnetic Field Strength Detection Low Threshold Alarm Bit	Chapter 7.3
PPT(9:0)	0x000	ABZ Resolution	Chapter 5.1
RD	0	Rotation Direction	Chapter 7.3
Z(15:0)	0x0000	Index Count	Chapter 7.2
ZD(1:0)	00	Data Width Selector	Chapter 5.3
ZL(1:0)	00	Leading/Trailing Edge Capture	Chapter 5.3

### 3 SPI

The KTH7823 product utilizes the SPI interface to enable reliable and efficient data communication between microcontrollers and peripheral devices. The SPI interface supports functionalities such as angle reading, configuration register reading, and configuration register writing.

#### 3.1 SPI timing

Figure 6: SPI Timing Diagram

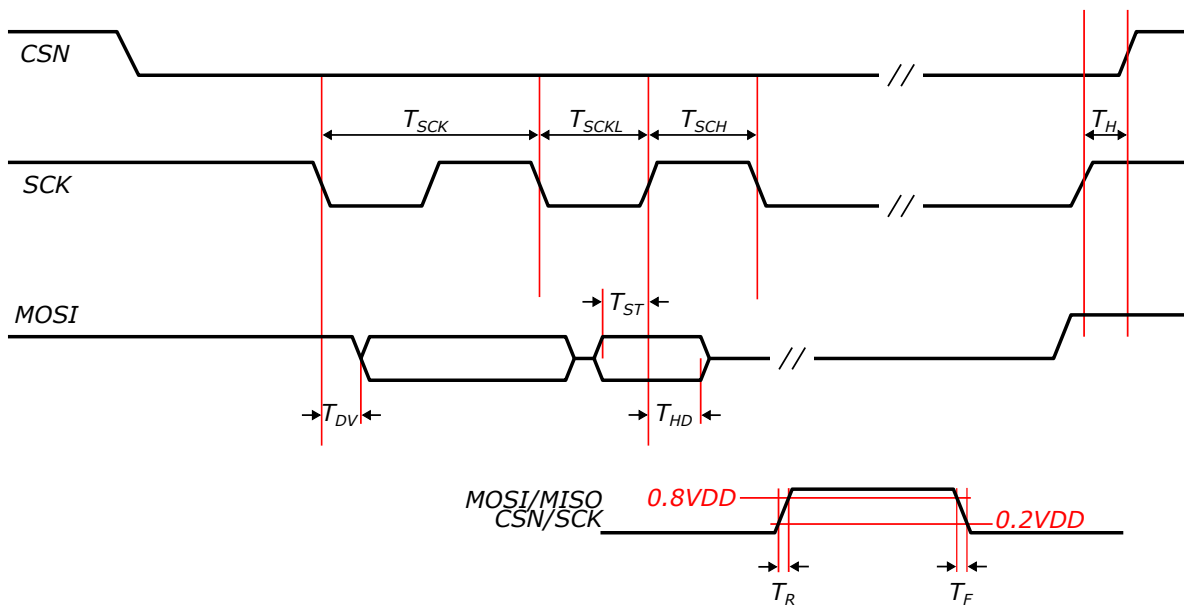

**Table 7: SPI Timing Parameters (with 20pF Load Condition)**

<b>Symbol</b>	<b>Description</b>	<b>Min. Value</b>	<b>Typical Value</b>	<b>Max. Value</b>	<b>Unit</b>
$T_{SCK}$	SCK Clock Period	100			ns
$T_{SCKL}$	Low Period of SCK Clock	50			ns
$T_{SCKH}$	High Period of SCK Clock	50			ns
$T_H$	Time interval between SCK and CSN rising edges	120			ns
$T_R$	Rise Time of Digital signal		10		ns
$T_F$	Fall Time of Digital signal		10		ns
$T_{DV}$	Data Valid Time of MISO			50	ns
$T_{ST}$	Setup Time of MOSI Data	50			ns
$T_{HD}$	Hold time of MOSI Data	50			ns

Figure 6 presents an SPI timing diagram, while Table 7 provides detailed information on the SPI timing parameters of the KTH7823 product under a 20pF load condition. This table includes symbols, descriptions, and the minimum, typical, and maximum values for each parameter, expressed in nanoseconds (ns). These parameters play a crucial role in defining the timing requirements for SPI communication, ensuring dependable data transfer between microcontrollers and peripheral devices when utilizing the KTH7823 product.

Table 7 specifically outlines the SPI timing parameters, featuring symbols, descriptions, and the minimum, typical, and maximum values for each parameter, measured in nanoseconds (ns). These parameters are instrumental in establishing the timing requirements for SPI communication, thereby facilitating reliable data transfer when employing the KTH7823 product.

The KTH7823 product employs the SPI interface, operating in CPOL = 1 and CPHA = 1 mode, to facilitate communication between microcontrollers and peripheral devices. Conforming to the SPI international standard, the interface incorporates four lines: SCK, MOSI, MISO, and CSN. Data transmission occurs through fixed-length 16-bit packets.

The SPI timing parameter table serves as a valuable resource for comprehending the correct utilization and debugging of hardware and firmware designs pertaining to the SPI interface. Adhering to these timing parameters is critical to ensuring reliable data communication through meticulous hardware and firmware design.

All aforementioned SPI parameters are implemented in the provided hardware and firmware, allowing users to configure and optimize them based on their specific application requirements. Our technical support team is readily available to assist users with any challenges encountered during usage.

In summary, the SPI interface of the KTH7823 product is a robust and versatile communication tool, suitable for a wide range of microcontrollers and peripheral devices. By comprehending and effectively employing these SPI timing parameters, users can maximize the product's performance and fulfill their specific application needs.

**Figure 7: SPI Command-Response Overlapped Structure**

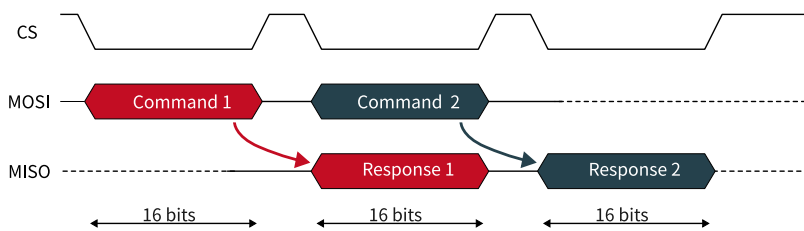

SPI communication adopts an overlapped structure that allows the transmission of a response from the previous command while sending the next command. Figure 7 illustrates an example of a single-device setup, where the host controls a KTH7823 slave device.



### 3.2 Reading Registers via SPI

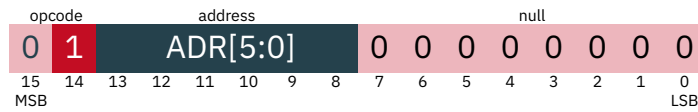

The operation of reading registers involves two 16-bit frames.

The first frame is the write request frame, comprising a 2-bit write command, a 6-bit register address, and 8 bits of zero padding. The second frame is the returned register value, formatted as XXXX – XXXX – 0000 – 0000.

The table below presents the instruction format for this operation. Starting from the most significant bit (MSB), the first 2 bits represent the opcode, the operation code of the instruction. The subsequent 6 bits denote the address, specifying the register's location. The remaining blank section represents invalid bits, padded with zeros.

### 3.3 Register Writing via SPI

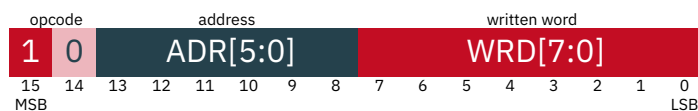

The KTH7823 chip provides the capability to write to registers via the SPI bus. Registers are programmable 8-bit storage units used to store specific configuration and control parameters, allowing customization of the chip's behavior and functionality.

The process of writing to registers via SPI involves two 16-bit frames. The first frame is the write request frame, consisting of a 2-bit write command (10), followed by a 6-bit register address and an 8-bit value. The write command instructs the chip to perform the write operation, the register address specifies which register to write to, and the value represents the data to be written. Data transmission starts from the Most Significant Bit (MSB).

The second frame is the returned acknowledgment frame, containing the value of the newly written register. The frame format is XXXX – XXXX – 0000 – 0000. This acknowledgment

frame serves as a response from the chip, confirming the successful writing of data into the register.

During the process of writing to registers via SPI, it is important to note that a minimum wait time of 20 milliseconds between the first frame and the second frame is required. This wait time ensures that the written data is correctly stored in the chip's non-volatile memory. Failing to wait for an adequate amount of time after the write request may result in reading the previous value of the register. Therefore, it is crucial to adhere to this wait time when performing register writing operations.

It is worth mentioning that this wait time is applicable only to write operations. For read register or read angle operations, no wait time is required.

The register values of the KTH7823 chip are automatically loaded during power-up as they are stored in the chip's non-volatile memory. This means that even after a power loss and subsequent power-up, the configuration and control parameters stored in the registers will remain unchanged without the need for reconfiguration.

To ensure long-term stability and reliability of the registers, the memory design of the KTH7823 chip is carefully engineered to withstand 1,000 write cycles and maintain reliable operation even in environments with a temperature of up to 125°C.

By utilizing register writing via SPI, you can easily configure and fine-tune various functionalities and behaviors of the KTH7823 chip to meet your specific requirements. For detailed information on the functionality and configuration options of each register, please refer to the official documentation and specifications of the KTH7823 chip.

### 3.4 Read Absolute Angle via SPI



When using SPI for reading the absolute angle from the KTH7823 angle sensor, the following general steps and principles are involved:

- (1) Set Communication Parameters: First, ensure that the SPI

communication parameters between the master device and the KTH7823 angle sensor are configured consistently. This includes parameters such as clock frequency, data width, and other relevant settings.

- (2) **Trigger Read Operation:** The master device initiates the read operation by pulling the chip select (CS) signal low and sending the appropriate read position command via MOSI. Pulling the chip select signal low signals the sensor to prepare for data transmission to the output buffer.
- (3) **Data Transmission and Reception Process:** Every microsecond, a new data bit is transmitted to the output buffer. The sensor sends the data bit to the master device serially through the MISO pin. The master device controls the data reception by utilizing the clock signal, ensuring the accurate reception of each data bit.
- (4) **Angle Value Interpretation:** Once the master device sends a sufficient number of clock counts, the KTH7823 sensor responds and provides angle data. By interpreting the received data, the corresponding absolute angle value can be obtained.

During the transmission process, it is recommended to keep the MOSI line at a low logic level to prevent interference signals such as 01, 10, and others, which could interrupt the transmission of angle data. This precautionary measure helps to ensure the stability and accuracy of the transmission.

To optimize the angle reading process and ensure that no information is lost, it is possible to reduce the number of clock counts. When a data output length of 12 bits is required, only 12 clock counts are needed to obtain the complete sensor resolution.

If a lower resolution is desired, the angle value can be read by sending fewer clock counts as the most significant bit is transmitted first. This method is known as the fast read mode, where the KTH7823 sensor continuously sends the same data until the data is refreshed. The fast read mode can improve the reading speed.

For a clearer understanding, the following diagram illustrates the process of reading the absolute angle via SPI:

**Figure 8: SPI Read Absolute Angle Process**

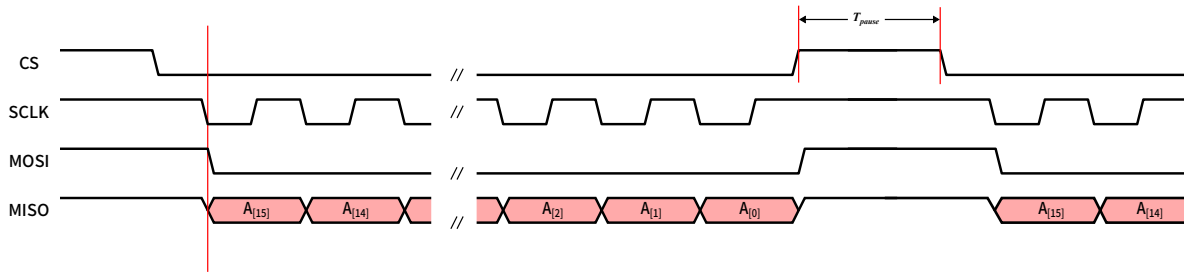

Figure 8 shows the connection between the master device and the KTH7823 angle sensor, illustrating the sequence of data bit transmission and reception. Note: The time interval  $T_{pause}$  between two consecutive communications must be greater than 150ns.

### 3.5 Disabling Register Configuration Functionality

During normal operation of the KTH7823 series, it is typical to only read the angle via SPI and not make any further register configurations. To support this, the WRDIS (Write Disable) register is provided. When WRDIS is set to 1, it prevents any register configurations from being made to the chip.

The WRDIS register, defined as follows, allows for the read-only mode:



When the WRDIS bit is set to 1, it disables any write operations to the registers of the KTH7823 chip. This ensures that the configuration remains fixed and only the angle can be read via the SPI interface. By enabling the read-only mode, it prevents accidental or unauthorized changes to the register settings, providing greater security and stability to the system.

It is important to note that changing the WRDIS register back to 0 re-enables register configurations, allowing modifications to the chip’s settings if necessary.

### 3.6 Read Angle with CRC checksum

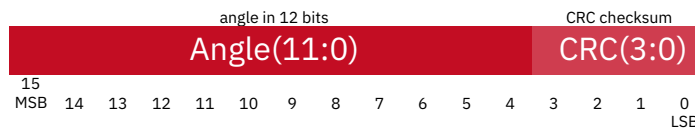

If you have selected a version of the chip with SPI output including CRC checksum, you can send the read position command described in the previous section to receive the SPI output with checksum on the MISO pin. The output frame format is as follows: first, a 12-bit position data with MSB first, followed by a 4-bit CRC checksum. The CRC checksum follows the CRC-4 / ITU standard with the polynomial formula  $X^4 + X + 1$ . The initial value is 00, the XOR result is 00, and both input and output are reversed (true). For example, if the position data is 0FF and the CRC checksum value is 2, the received data will be 0FF2. If you have any requirements for CRC checksum programming during your usage, please contact the Field Application Engineer (FAE) for assistance.

#### Demonstrating CRC Calculation for KTH7823

**Step 1: Data Input** Consider a 12-bit hexadecimal data *3EB*, which, when converted to binary, yields 0011 1110 1011. To facilitate subsequent calculations, pad the data to 16 bits, resulting in 0000 0011 1110 1011.

**Step 2: Bit Reversal** Prior to initiating the CRC computation, reverse each 8-bit segment of the data. This is required because CRC calculations proceed from the least significant bit (LSB) to the most significant bit (MSB). Thus, 0000 0011 1110 1011 becomes 1100 0000 1101 0111.

**Step 3: Polynomial Specification** CRC relies on polynomial mathematics. The generator polynomial for KTH7823 is  $X^4 + X + 1$ , or mathematically,  $1X^4 + 0X^3 + 0X^2 + 1X + 1$ . Extracting its coefficients provides the binary representation 10011.

**Step 4: XOR Division** To begin the XOR division, append four zeros at the end of the reversed data for bit-alignment with the polynomial. Perform XOR operations as follows:

1. Align the data with the polynomial.
2. Execute XOR operations.
3. Continue the process until all bits are processed.

```

1 1 0 0 0 0 0 0 1 1 0 1 0 1 1 1 0 0 0 0
1 0 0 1 1
-----
0 1 0 1 1 0 0 0 1 1 0 1 0 1 1 1 0 0 0 0
  1 0 0 1 1
  -----
  0 0 1 0 1 0 0 1 1 0 1 0 1 1 1 0 0 0 0
    1 0 0 1 1
    -----
    0 0 1 1 1 1 1 0 1 0 1 1 1 0 0 0 0
      1 0 0 1 1
      -----
      0 1 1 0 0 0 1 0 1 1 1 0 0 0 0
        1 0 0 1 1
        -----
        0 1 0 1 1 1 0 1 1 1 0 0 0 0
          1 0 0 1 1
          -----
          0 0 1 0 0 0 1 1 1 0 0 0 0
            1 0 0 1 1
            -----
            0 0 0 1 0 1 1 0 0 0 0
              1 0 0 1 1
              -----
              0 0 1 0 1 0 0 0
                1 0 0 1 1
                -----
                0 0 1 0 1 0 0 0
                  1 0 0 1 1
                  -----
                  0 0 1 1 1 0
                    1 1 1 0
                    -----
                    1 1 1 0

```

**Step 5: Output Reversal** The final result of 1110 is reversed to 0111. Note that for CRC values exceeding 8 bits, each 8-bit segment is individually reversed. However, for this 4-bit CRC, reversal occurs within the 4 bits.

**Step 6: Final Output** KTH7823 concatenates the original 16-bit data with the 4-bit CRC result, yielding 0000 0011 1110 1011 0111, which is then transmitted to the user.

## 4 Angle Reading via SSI

SSI (Synchronous Serial Interface) is a synchronous serial interface protocol used for data transfer between digital systems.

**Figure 9: SSI Interface Timing Diagram**

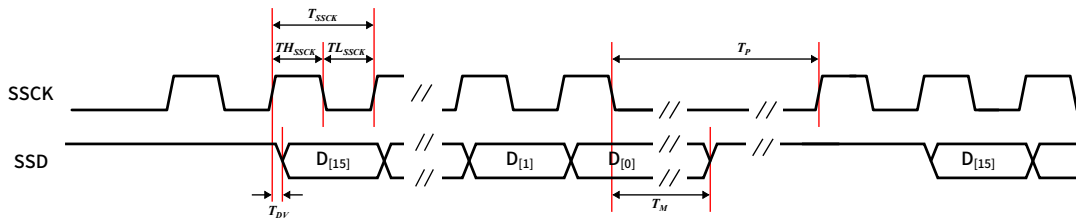

**Table 8: SSI Interface Timing Parameters**

Symbol	Description	Typical Value	Maximum Value	Unit
$t_{DV}$	SSD Data Valid Time		15	ns
$T_{DV}$	SSCK Clock Period	0.66	16	$\mu$ s
$T_{LSCK}$	Low Period of SSCK Clock	0.33	8	$\mu$ s
$T_{HSCK}$	High Period of SSCK Clock	0.33	8	$\mu$ s
$T_M$	SSD Monoflop Time	33		$\mu$ s
$T_p$	Pause Time	53		$\mu$ s

Table 8 shows the timing specifications for the SSI interface.

$T_M$  represents the Monoflop Time, also known as the timeout period. It sets a time limit during data transfer to determine the maximum duration of the data transfer. If the data transfer is not completed or does not reach the next state within the specified  $T_M$  time, it will be considered a timeout. A timeout may indicate a transfer error or other issues that require appropriate error handling. By properly setting  $T_M$ , timely detection and handling of transfer anomalies can be ensured, thereby improving the reliability and stability of the system.

$T_p$  represents the Pause Time, which is the interval during which the system waits after the completion of data transfer before entering the next state. The Pause Time is used to stabilize data transfer, wait for device readiness, or perform other necessary

operations. During  $T_P$ , the system can perform necessary verification, processing, or preparation work to ensure smooth progress of the next round of transfer. By properly setting  $T_P$ , efficient utilization of system resources and good transfer performance can be achieved.

When reading the angle via SSI with the KTH7823, the data bits are transmitted in a high-order priority. Every microsecond, a new data bit is transferred to the output buffer. The read operation is triggered by raising the SSCK signal. A complete read requires a maximum of 17 clock cycles. The first clock cycle is a virtual clock used to initiate the transfer. The most significant bit of the data is transmitted in the second clock cycle. If the data

length is less than 16 bits, the output data is extended to a full 16 bits by padding with zeros. Therefore, angle reading can be done in less than 16 clock cycles. When a trigger event is detected, the data will be held in the output buffer until the falling edge of the LSB bit 0 and the monoflop time have passed.

The KTH7823 operates as a slave device to an external SSI master and supports only angle reading operations. It is not possible to read or write registers via the SSI interface.



## 5 ABZ Output

The KTH7823 provides angle position output through the incremental interface ABZ. The ABZ interface is configured with a resolution of 12 bits, which means there are 4096 steps per revolution or 1024 pulse periods per revolution (PPT) for the AB signals.

The phase difference between the A and B signals can indicate the direction of rotation. In the clockwise direction, the A signal leads and the B signal follows, while in the counterclockwise direction, the B signal leads and the A signal follows. During power-up, all three ABZ signals will be held at a high level.

When the magnet located directly above the chip (from a top view perspective) rotates counterclockwise (CCW), the rising edge of the B signal will lead the rising edge of the A signal by 1/4 of a period. Conversely, when rotating clockwise (CW), the rising edge of the A signal will lead the rising edge of the B signal by 1/4 of a period. The phase difference between the A and B signals changes with the direction of rotation of the magnet.

**Figure 10: ABZ Output Timing**

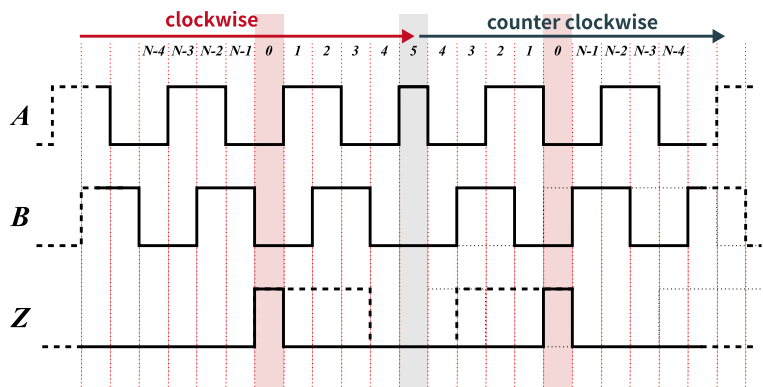

0x04	PPT(1:0)		ZL(1:0)		ZD(1:0)			
	7	6	5	4	3	2	1 0	
0x05	PPT(9:2)							
	7	6	5	4	3	2	1 0	
0x08						ABZLIMIT(1:0)		
	7	6	5	4	3	2	1 0	
	MSB							LSB

## 5.1 ABZ Output Resolution

The KTH7823's ABZ incremental output can provide angle position output with a customizable integer resolution of up to 1024 pulse periods per revolution (PPT). The resolution can be defined by programming the MTP bits **PPT(9:0)** within the chip. Refer to Table 9 for the corresponding resolutions in pulses per revolution and steps per revolution.

**Table 9: ABZ Resolution for PPT**

<b>PPT(9:0)</b>	<b>pulses per turn</b>	<b>steps per turnb</b>
0	1	4
1	2	8
2	3	12
...	...	...
1021	1022	4088
1022	1023	4092
1023	1024	4096

## 5.2 ABZ Output Frequency Setting

The maximum output frequency for the ABZ output of the KTH7823 is 16 MHz. The highest output frequency can be adjusted by setting the ABZLIMIT parameter. Refer to Table 10 for the corresponding highest output frequencies.

**Table 10: ABZLIMIT Setting for Highest Output Frequency**

<b>ABZLIMIT</b>	<b>Highest Frequency</b>
0	16 MHz
1	8 MHz
2	4 MHz
3	2 MHz
4	1 MHz
5	0.5 MHz
6	0.25 MHz
7	0.125 MHz

### 5.3 Zero Index Signal Z

The Z signal (also known as the index signal or zero reference signal) has a rising edge that occurs once per revolution at the zero position. The position and width of the Z signal can be programmed using the **ZL(1:0)** and **ZD(1:0)** bits in register 0x4. By default, both ZL and ZD parameters are set to 00.

**Figure 11: Width (ZL) and Position (ZD) of the Z Signal in ABZ**

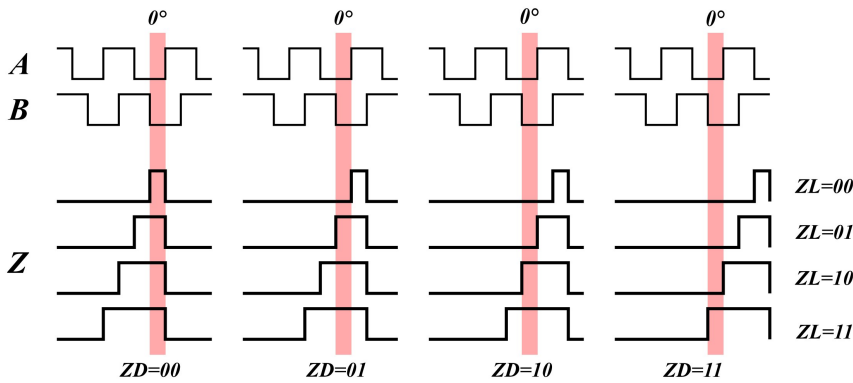

### 5.4 ABZ Hysteresis

ABZ incremental output hysteresis refers to the introduction of a lag effect on the ABZ output signals to prevent false transitions and improve the system’s immunity to interference. Hysteresis means that the output signal must exceed a specific threshold before changing its state. This lag effect helps reduce the impact of noise and other interferences on the output signal. When the input signal changes, the output signal does not immediately follow the change but requires

surpassing a threshold to change its state. Setting this threshold makes the system less sensitive to small noise and interferences, thereby enhancing stability and accuracy.

By introducing ABZ incremental output hysteresis, errors can be reduced, and the system’s immunity to interference can be improved. This is particularly important for applications that require high precision and stability, especially in noisy environments or in the presence of interferences. By introducing ABZ incremental output hysteresis, errors can be reduced, and the system’s immunity to interference can be improved. This is particularly important for applications that require high precision and stability, especially in noisy environments or in the presence of interferences.

## 6 PWM Absolute Position Output

The KTH7823 provides a single-line 14-bit absolute value PWM output mode, as shown in Figure 12. The PWM output is the default output form of pin 9.

The logic signal of the PWM output is directly proportional to the magnetic angle, with a PWM frequency of 972 Hz. An angle of  $0^\circ$  corresponds to a duty cycle of  $32/(16384 + 64)$ , and an angle of  $360^\circ$  corresponds to a duty cycle of  $(16384 + 32)/(16384 + 64)$ . The resolution is 14 bits. The angle corresponding to any duty cycle can be calculated using Equation 2.

$$Ang = \frac{360}{16384} \left[ \frac{(16384 + 64) \cdot t_{ON}}{t_{ON} + t_{OFF}} - 32 \right] \quad (2)$$

where  $Ang$  is the angle in degrees,  $t_{ON}$  is the ON time of the PWM signal, and  $t_{OFF}$  is the OFF time of the PWM signal.

**Figure 12: PWM Timing**

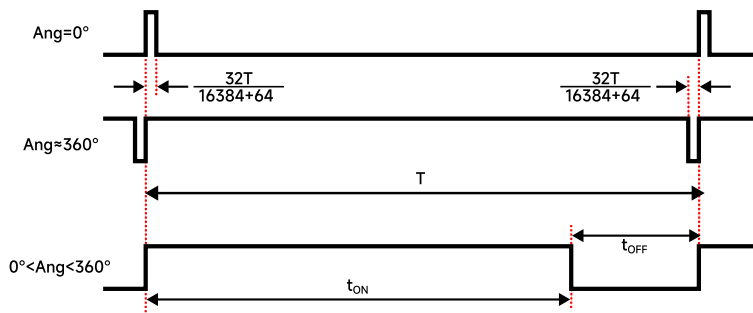

# 7 System Operation Settings

## 7.1 Rotation Direction

Figure 13: Rotation Direction

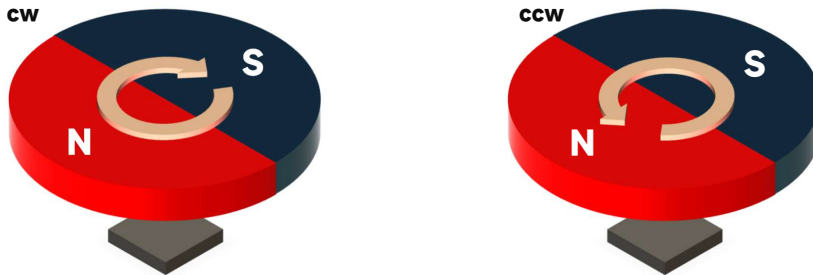

The RD register defines the relationship between the output angle increment and the rotation direction. By default, RD=1, when the magnet (viewed from above) rotates clockwise (CW) when viewed from above, the output angle of the chip increases.



## 7.2 Zero Point Setting

The zero point of the sensor can be programmed using the Z register (15:0), which defines the position of the zero point. This value is applicable to all types of angle outputs and can be programmed with a 16-bit resolution.

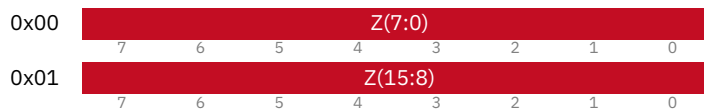

## 7.3 Threshold Detection Settings

To facilitate user applications, the KTH7823 series allows for the configuration of both low threshold magnetic field alarms (mgl) and high threshold magnetic field alarms (mgh). For example, when mgh(2:0) is set to 1, if the magnetic field exceeds 34mT, the MGH pin will be pulled high. When the magnetic field decreases below 28mT, the MGH pin will be pulled low. Similarly, when mgl(2:0) is set to 0, if the magnetic field falls below 18mT, the MGL pin will be pulled high, and when the magnetic field increases above 24mT, the MGL pin will be pulled low.

The threshold detection settings are configured using the following register:



The values of mgh(2:0) and mgl(2:0) correspond to specific magnetic field thresholds and pin behavior. The table below illustrates the corresponding magnetic field intensities for each threshold configuration:

**Table 11: Magnetic Field Intensity Corresponding to High and Low Threshold Alarms**

mgh(2:0)	MGH Rising	MGH Falling	mgl(2:0)	MGL Rising	MGL Falling
0	23mT	16mT	0	18mT	24mT
1	34mT	28mT	1	30mT	36mT
2	47mT	40m	2	42mT	48mT
3	58mT	52mT	3	54mT	60mT
4	70mT	63mT	4	65mT	71mT
5	81mT	75mT	5	77mT	83mT
6	92mT	86mT	6	88mT	94mT
7	103mT	97mT	7	99mT	105mT

By configuring the mgh(2:0) and mgl(2:0) registers, users can set specific threshold levels for magnetic field detection and customize the behavior of the MGL and MGH pins accordingly. This feature allows for the implementation of magnetic field monitoring and trigger-based actions in applications where specific thresholds need to be met or exceeded.

### 7.4 Sensor Horizontal Position Calibration

When we install the KTH7823 sensor at the center position of a magnet or when the design requires the sensor to be mounted on the side of the magnet’s center, there is a deviation between the sensor’s output magnetic field strength and the magnet’s position. This is due to the non-linear relationship between the sensor’s output and the actual magnet position, which is caused by the uneven distribution of the magnetic field on the magnet’s surface, resulting in a non-linear relationship between the sensor’s output and the actual magnet position. One of the

main reasons is that the tangential magnetic field (along the direction of the magnet's surface) is usually weaker than the radial magnetic field (perpendicular to the magnet's surface), as shown in Figures 14 and 15.

**Figure 14: Illustration of Sensor Located in Tangential Magnetic Field**

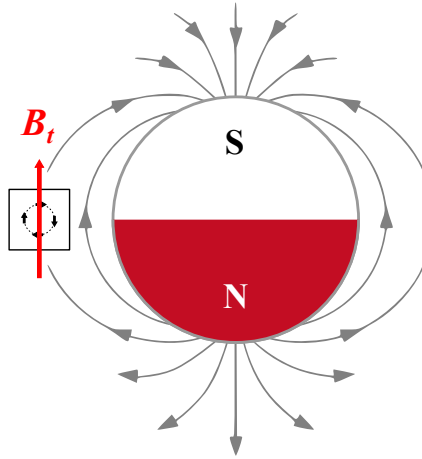

**Figure 15: Illustration of Sensor Located in Radial Magnetic Field**

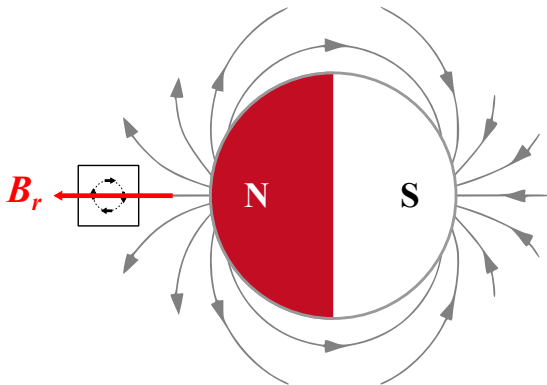

To better calibrate the sensor and detect the magnet's position, the KTH7823 introduces the concept of magnetic field ratio  $\mu$ , which is an important parameter used to describe the relationship between magnetic field intensity and the actual magnet position. The magnetic field ratio  $\mu$  represents the ratio between the maximum radial magnetic field  $B_r$  and the maximum tangential magnetic field  $B_t$ , and it is calculated as follows:

$$\mu = \frac{B_r}{B_t} \quad (3)$$

To simplify the calibration process, the KTH7823 introduces two parameters: Xtrim, Ytrim, and GAINtrim(7:0):

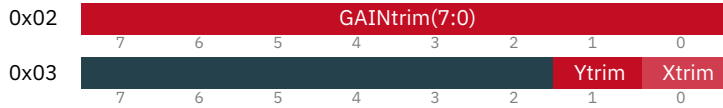

These parameters are used to adjust the sensitivity of the sensor in the X and Y directions for precise calibration.

The Xtrim and Ytrim parameters serve the specific function of fine-tuning the sensor’s sensitivity along the X and Y axes for precise calibration. By default, both axes exhibit identical sensitivity levels, configured at a value of 0x10000, equivalent to 256 in decimal notation. This ensures a uniform signal sensitivity across both directional axes. To selectively attenuate the signal sensitivity along the X-axis while maintaining the Y-axis sensitivity, assign a value of 1 to the Xtrim parameter and 0 to the Ytrim parameter. Conversely, to reduce the Y-axis sensitivity while retaining the X-axis sensitivity, set the Xtrim parameter to 0 and the Ytrim parameter to 1.

**Figure 16: Illustration of Chip Placement Orientation and Setting of Xtrim and Ytrim Parameters**

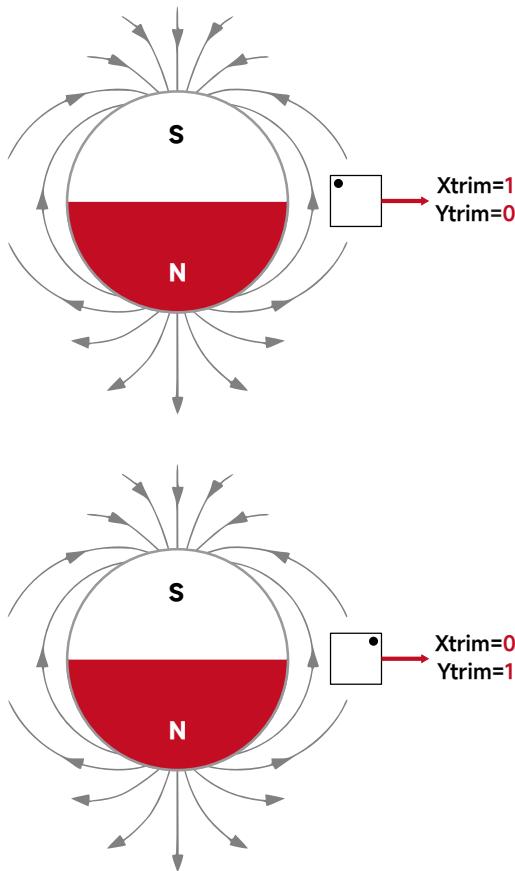

The parameter GAINtrim(7:0), an 8-bit integer value ranging



**Table 12: Examples of GAINtrim Settings**

<b>Magnetic Field Ratio</b> $\mu$	<b>Register GAINtrim</b> (7:0)
1.0	0
1.5	85
2.0	128
2.5	154
3.0	171
3.5	183
4.0	192
4.5	199
5.0	205

from 0 to 255, governs the specific extent of sensitivity reduction. Lower GAINtrim values are associated with diminished sensitivity, leading to a less pronounced signal response upon magnetic field variations. Conversely, higher GAINtrim values result in augmented sensitivity, leading to a more pronounced signal response. Thus, the GAINtrim parameter offers a versatile means for tailoring the sensor's sensitivity based on specific application requirements.

For calibration purposes, a streamlined approach involves positioning the sensor on a plane orthogonal to the axis of magnet rotation. Upon rotating the magnet, the sensor sequentially intersects with radial and tangential magnetic fields. The magnetic field ratio  $\mu$  can be empirically determined by capturing the maximum amplitude variations of the Hall signal along the X and Y axes. Here,  $B_r$  and  $B_t$  represent the larger and smaller amplitudes, respectively.

Refer to Table 12 for a compilation of GAINtrim settings alongside corresponding magnetic field ratios  $\mu$  under varying error angles. The table serves as a comprehensive guide, enabling users to select the optimal GAINtrim settings to achieve the intended sensitivity reduction in diverse applications.

## 8 Packaging

The KTH7823 sensor is available in a specific package to ensure proper protection and compatibility with various applications. The packaging information is provided in Figure 17.

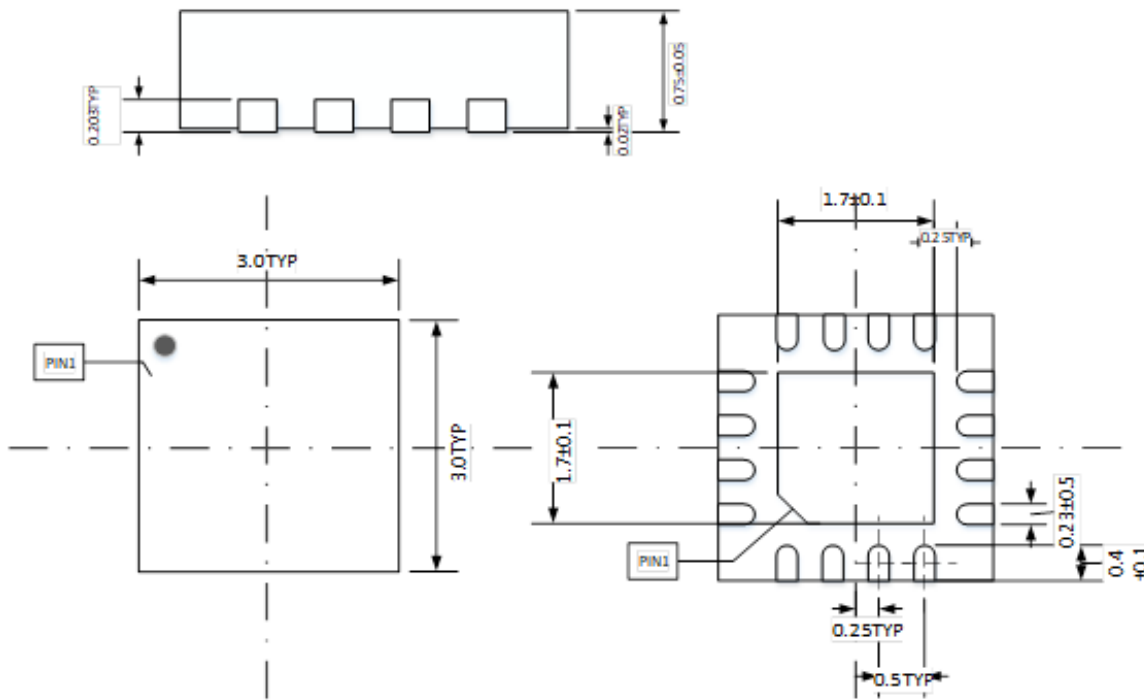
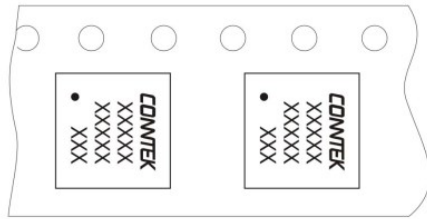
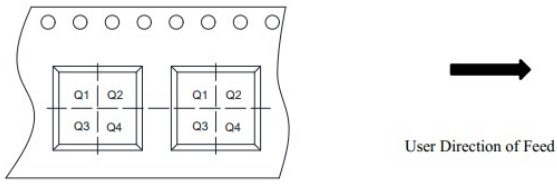

**Figure 17: Packaging Information for KTH7823**

The package type and dimensions are indicated in the figure, along with additional details such as the pinout configuration and marking information. This packaging design allows for easy integration of the sensor into different systems and ensures its durability during transportation and handling.



Quadrant Assignments For PIN1 Orientation In Tape



Pin1	Pin1 Quadrant	<input checked="" type="checkbox"/> Q1	<input type="checkbox"/> Q2	<input type="checkbox"/> Q3	<input type="checkbox"/> Q4
------	---------------	--	-----------------------------	-----------------------------	-----------------------------

## 10 Soldering Temperature Profile

During the soldering process, it is essential to follow the recommended temperature profile to ensure reliable and consistent solder joints. The soldering temperature profile is depicted in Figure 18.

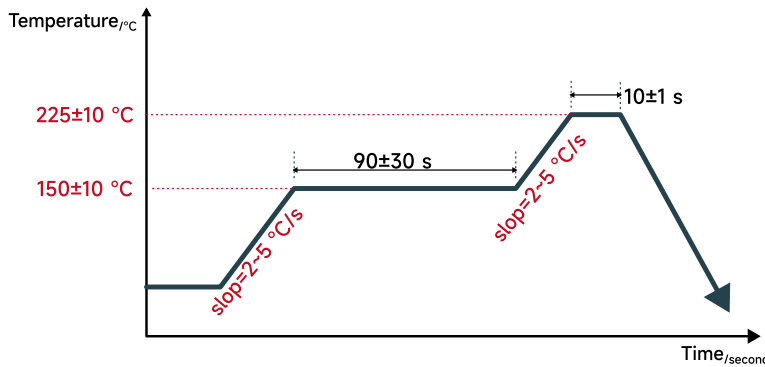

**Figure 18: Soldering Temperature Profile for KTH7823**

This temperature profile shows the recommended temperature ranges and duration for preheating, soldering, and cooling stages. Adhering to this temperature profile helps maintain the integrity of the sensor and achieve proper soldering results, ensuring the sensor’s reliability and performance.

## 11 Model Selection Guide

**Table 13: Model List**

Model	Noise (1 sigma)	Output Interface	Time Constant $\tau$ (ms)	Operating Field	Recommended Application
KTH7821	0.240°	SPI, SSI, PWM, ABZ	0.004	30-150mT	General
KTH7822	0.059°	SPI, SSI, PWM, ABZ	0.030	30-150mT	General
KTH7823	0.015°	SPI, SSI, PWM, ABZ	0.510	30-150mT	General
KTH7824	0.004°	SPI, SSI, PWM, ABZ	16.300	40-150mT	General

## Disclaimer

This technical document is provided by CONNTEK for informational purposes only. The information contained in this document is provided "as is" and without warranties of any kind, either expressed or implied. CONNTEK makes no representations or warranties about the accuracy, completeness, or suitability of the information contained in this document. Under no circumstances shall CONNTEK be liable for any direct, indirect, special, incidental, or consequential damages arising out of the use or inability to use the information contained in this document. Users are responsible for ensuring that their use of any information contained herein complies with all applicable laws, regulations, and guidelines. CONNTEK reserves the right to make changes to this disclaimer at any time and without notice.

## Copyright

Copyright © CONNTEK. All rights reserved.

This document and its contents are protected by copyright law and may not be reproduced or transmitted in any form or by any means without the prior written consent of CONNTEK.

## Contact

Headquarters Address  
Room B501, Huachuang Park  
Sports Street, Huada Street  
Quanzhou City, P.R.CHINA

Business Number: +86(0)755-86006609

Email: [support@conntek.com.cn](mailto:support@conntek.com.cn)