

Features

- TMR+CMOS Monolithic Structure
- Low power Consumption
 - 50Hz Version: 160nA@3.0V (typical)
 - Continuous Version: 1.9uA@3.0V (typical)
- Supply Voltage: 1.8V~5.5V
- High Magnetic Sensitivity
 - $B_{OPS}=45Gs$ $B_{RPS}=36Gs$
 - $B_{OPS}=30Gs$ $B_{RPS}=21Gs$
 - $B_{OPS}=18Gs$ $B_{RPS}=12Gs$
 - $B_{OPS}=9Gs$ $B_{RPS}=6Gs$
- Magnetic Type: Unipolar (South-Pole)
- Push-Pull CMOS Output
- Package: SOT-23-3L (MSL1)
TO-92S
- Operating Temperature: $-40^{\circ}C \sim 125^{\circ}C$
- High ESD Rating: HBM 8KV
- RoHS Compliant

Application

- Water, Electric and Gas Utility Meters
- Non-Contact Detection
- Door, Lids and Tray Position Switches
- Linear and Rotary Position Detection

Typical Application Circuit

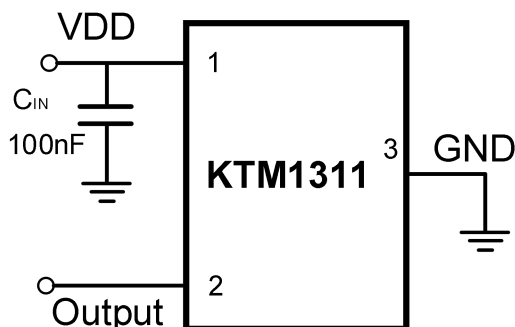

Note: C_{IN} is for stabilization and to strengthen the noise immunity, the recommended capacitance is 100nF typical and should be placed as close to the supply pin as possible.

Descriptions

The KTM1311 is an unipolar(south-pole) magnetic switch integrated with Tunneling Magnetoresistance (TMR) technology and CMOS process for use in industrial and consumer switch applications. The IC internally includes a TMR bridge, a voltage regulator for operation with supply voltage from 1.8V to 5.5V, digital logic control module, threshold adjustment module, Schmitt trigger and a push-pull output. If the magnetic flux density parallel to the part marking surface is larger than operating point (B_{OPS}), the output will be turned on; if it is less than releasing point (B_{RPS}), the output will be turned off.

The KTM1311 family provides a variety of package to customers: SOT-23-3L for surface mount and TO-92S flat for through-hole mount. All package are RoHS compliant.

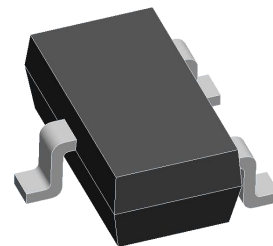

SOT-23-3L



TO-92S

Pin Descriptions

SOT-23-3L

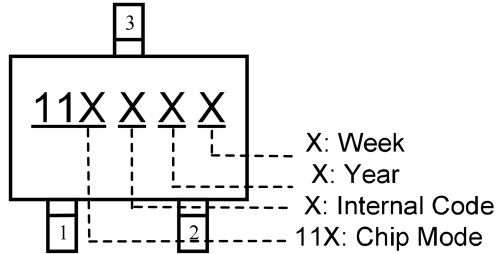
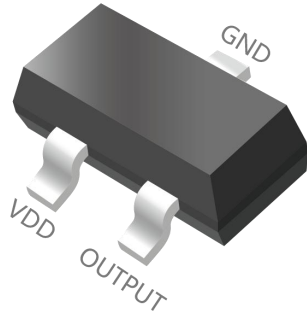

Top view

Pin Name	Pin Number	Function
VDD	1	Power Supply Input
OUTPUT	2	Output Ground Pin
GND	3	Ground Pin

TO-92S

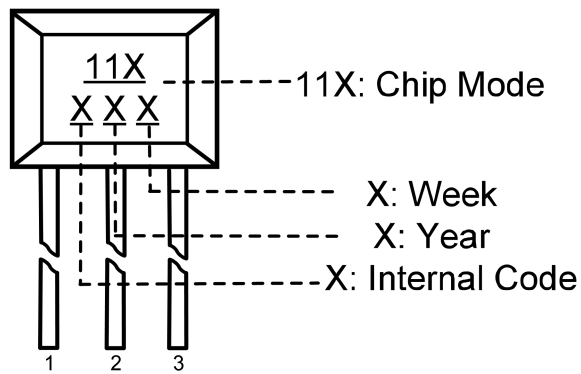
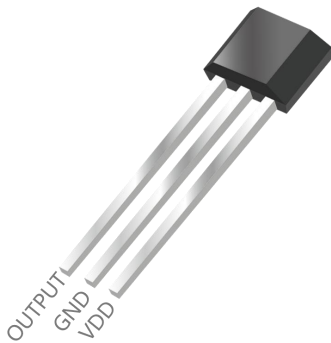

Top view

Pin Name	Pin Number	Function
VDD	3	Power Supply Input
GND	2	Ground Pin
OUTPUT	1	Output Pin

Block Diagram

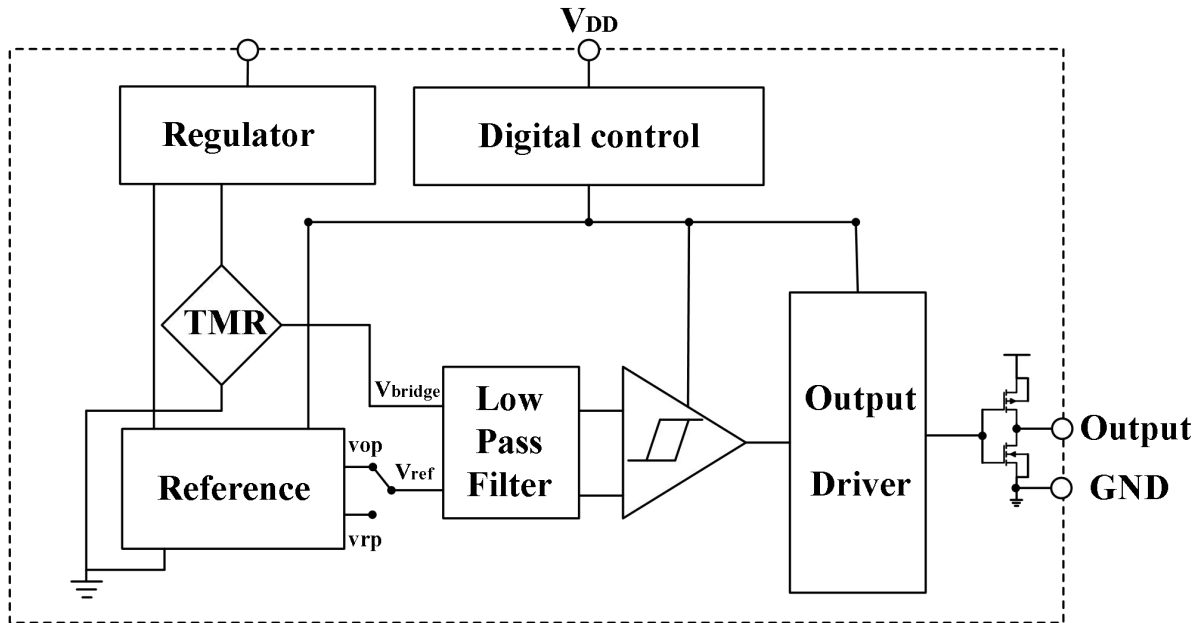

Output Switching Characteristics

To operate the TMR switch, the magnetic field should be applied to the sensor with sufficient magnetic flux density and correct direction.

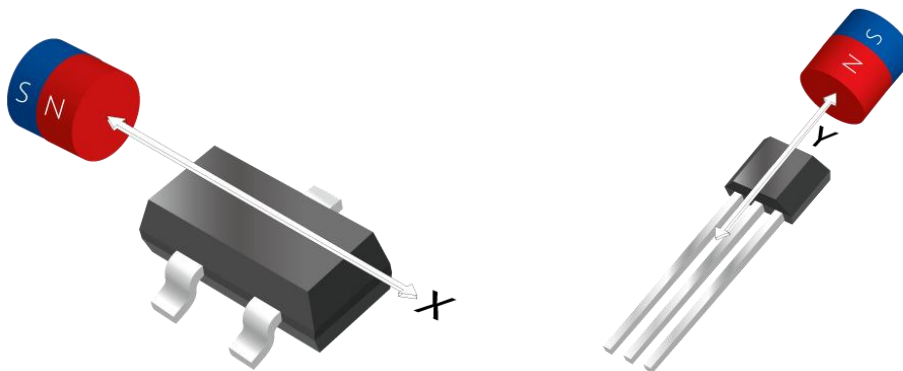

As shown in the figure below, a horizontal magnetic field parallel to the package can be detected.

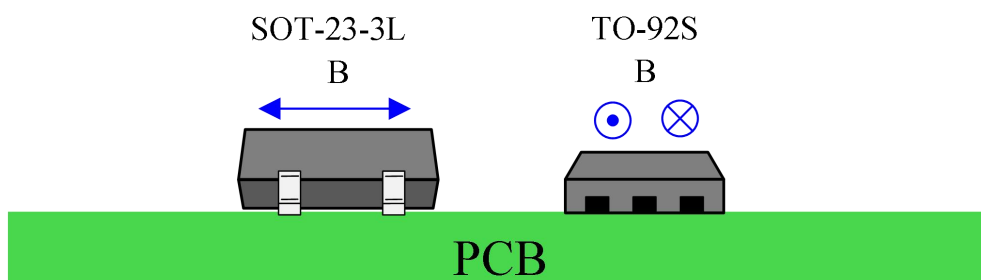

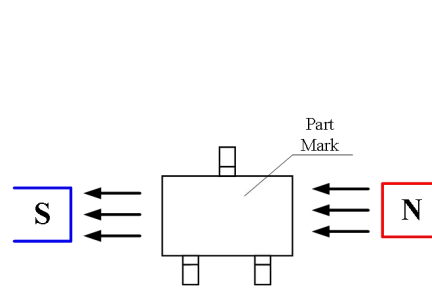
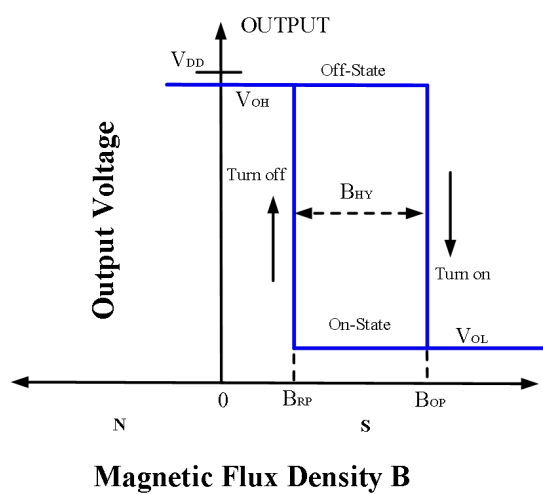

SOT-23-3L

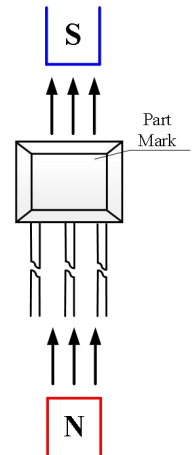

TO-92S

Product Name Structure

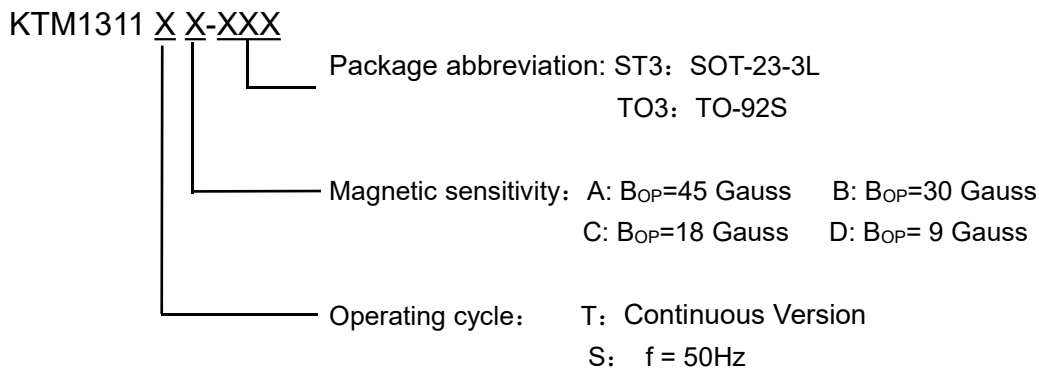

Absolute Maximum Ratings (@T_A=+25°C, unless otherwise specified)

Symbol	Parameter	Value	Unit
V _{DD}	Supply Voltage Dissipation	6	V
V _{DD_REV}	Reverse voltage (VDD)	-0.3	V
I _{OUTPUT}	Output Current	5	mA
B	Magnetic Flux Density	3000@<5min	Gauss
T _{STG}	Storage Temperature Range	-50~+150	°C
T _J	Maximum Junction Temperature	+150	°C
ESD HBM	Human Body Model ESD Capability	8000	V
T reflow	Reflow Temperature (MAX)	+260	°C

Note: Exceeding the absolute maximum ratings may cause permanent damage. Exposure to absolute-maximum rated conditions for extended periods may affect device reliability.

Recommended Operating Range (@T_A=+25°C, unless otherwise specified)

Symbol	Parameter	Conditions	Value	Unit
V _{DD}	Supply Voltage	Operating	1.8~5.5	V
T _A	Operating temperature Range	Operating	-40~125	°C

Electronics Characteristics (@T_A=+25°C, V_{DD}=3.0V, unless otherwise specified)

KTM1311SX Series						
Symbol	Parameter	Condition	Min.	Typ.	Max.	Unit
V _{DD}	Supply Voltage	Operating	1.8	—	5.5	V
V _{OL}	Output Low Voltage (On)	I _{OUT} =1mA	—	0.008	0.05	V
V _{OH}	Output High Voltage (Off)	I _{OUT} =1mA	V _{DD} -0.05	V _{DD} -0.015	—	V
I _{DD(AVG)}	Average Supply Current	T _A =+25°C, V _{DD} =3.0V	—	160	—	nA
I _{DD(Awake)}	Awake Supply Current	T _A =+25°C, V _{DD} =3.0V	—	1.9	—	μA
I _{DD(Sleep)}	Sleep Supply Current	T _A =+25°C, V _{DD} =3.0V	—	148	—	nA
T _{AWAKE}	Awake Time	Operating	—	40	—	μs
T _{PERIOD}	Period	Operating	—	20	—	ms

KTM1311TX Series						
Symbol	Parameter	Condition	Min.	Typ.	Max.	Unit
V _{DD}	Supply Voltage	Operating	1.8	—	5.5	V
V _{OL}	Output Low Voltage (On)	I _{OUT} =1mA	—	0.008	0.05	V
V _{OH}	Output High Voltage (Off)	I _{OUT} =1mA	V _{DD} -0.05	V _{DD} -0.015	—	V
I _{DD(AVG)}	Awake Supply Current	T _A =+25°C, V _{DD} =3.0V	—	1.9	—	μA
F _S	Sampling Frequency	Operating	—	5000	—	Hz

Magnetic Characteristics (T_A=25°C, VDD=3.0V, unless otherwise noted)

Symbol	Characteristics	Condition	Min.	Typ.	Max.	Unit
KTM1311XA Series						
B _{OPS}	Magnetic threshold operate point	TA=+25°C, VDD=3.0V	40	45	50	Gauss
B _{RPS}	Magnetic threshold release point	TA=+25°C, VDD=3.0V	31	36	41	
B _{HY} (B _{OPX} - B _{RPX})	Magnetic hysteresis		-	9	-	

Symbol	Characteristics	Condition	Min.	Typ.	Max.	Unit
KTM1311XB Series						
B _{OPS}	Magnetic threshold operate point	TA=+25°C, VDD=3.0V	26	30	36	Gauss
B _{RPS}	Magnetic threshold release point	TA=+25°C, VDD=3.0V	16	21	26	
B _{HY} (B _{OPX} - B _{RPX})	Magnetic hysteresis		-	9	-	

Symbol	Characteristics	Condition	Min.	Typ.	Max.	Unit
KTM1311XC Series						
B _{OPS}	Magnetic threshold operate point	TA=+25°C, VDD=3.0V	15	18	24	Gauss
B _{RPS}	Magnetic threshold release point	TA=+25°C, VDD=3.0V	9	12	15	
B _{HY} (B _{OPX} - B _{RPX})	Magnetic hysteresis		-	6	-	

Symbol	Characteristics	Condition	Min.	Typ.	Max.	Unit
KTM1311XD Series						
B _{OPS}	Magnetic threshold operate point	TA=+25°C, VDD=3.0V	6	9	12	Gauss
B _{RPS}	Magnetic threshold release point	TA=+25°C, VDD=3.0V	3	6	9	
B _{HY} (B _{OPX} - B _{RPX})	Magnetic hysteresis		-	3	-	

Order Information

Part Numbers	Package	Number of Pins	Bop	Operating Frequency	Temperature
KTM1311TA-ST3	SOT-23-3L	3	45Gauss	Continuous	-40°C~125°C
KTM1311TB-ST3	SOT-23-3L	3	30Gauss	Continuous	-40°C~125°C
KTM1311TC-ST3	SOT-23-3L	3	18Gauss	Continuous	-40°C~125°C
KTM1311TD-ST3	SOT-23-3L	3	9Gauss	Continuous	-40°C~125°C
KTM1311SA-ST3	SOT-23-3L	3	45Gauss	50Hz	-40°C~125°C
KTM1311SB-ST3	SOT-23-3L	3	30Gauss	50Hz	-40°C~125°C
KTM1311SC-ST3	SOT-23-3L	3	18Gauss	50Hz	-40°C~125°C
KTM1311SD-ST3	SOT-23-3L	3	9Gauss	50Hz	-40°C~125°C
KTM1311TA-TO3	TO-92S	3	45Gauss	Continuous	-40°C~125°C
KTM1311TB-TO3	TO-92S	3	30Gauss	Continuous	-40°C~125°C
KTM1311TC-TO3	TO-92S	3	18Gauss	Continuous	-40°C~125°C
KTM1311TD-TO3	TO-92S	3	9Gauss	Continuous	-40°C~125°C
KTM1311SA-TO3	TO-92S	3	45Gauss	50Hz	-40°C~125°C
KTM1311SB-TO3	TO-92S	3	30Gauss	50Hz	-40°C~125°C
KTM1311SC-TO3	TO-92S	3	18Gauss	50Hz	-40°C~125°C
KTM1311SD-TO3	TO-92S	3	9Gauss	50Hz	-40°C~125°C

PACKAGE OUTLINE DIMENSIONS

SOT-23-3L

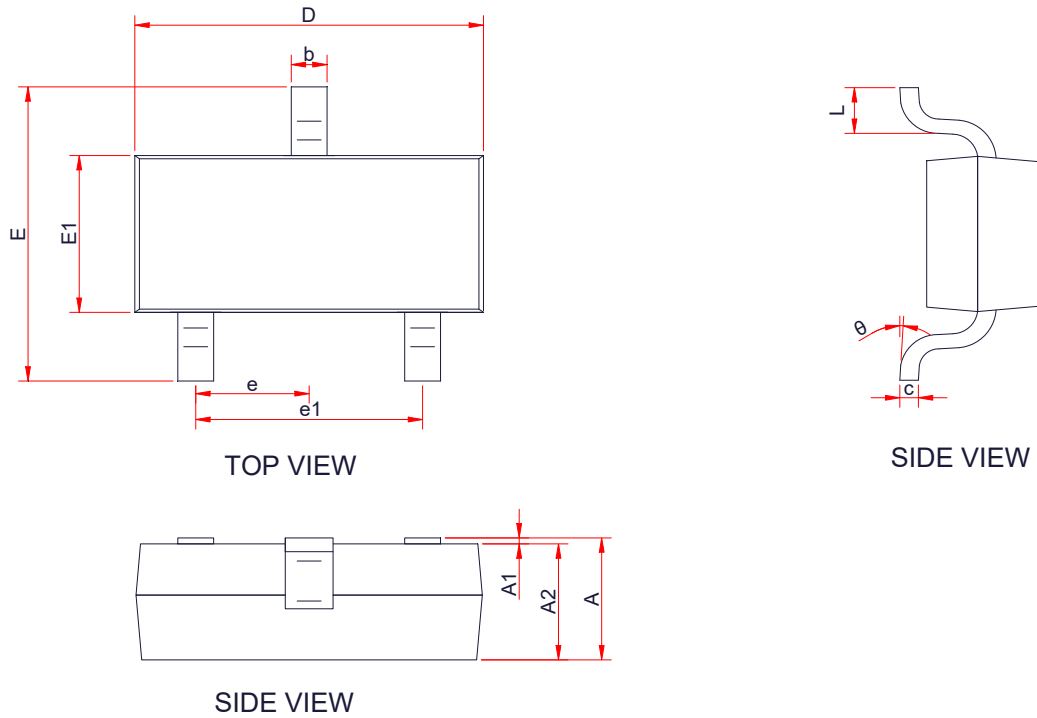

Symbol	Dimensions in Millimeters		
	Min.	Typ.	Max.
A	-	-	1.25
A1	0.00	-	0.1
A2	1.00	1.10	1.15
b	0.30	-	0.50
c	0.10	-	0.20
D	2.82	2.95	3.02
E	2.65	2.80	2.95
E1	1.50	1.65	1.70
e	0.85	0.95	1.05
e1	1.80	1.90	2.00
L	0.30	0.45	0.60
θ	0 °	-	8 °

TO-92S

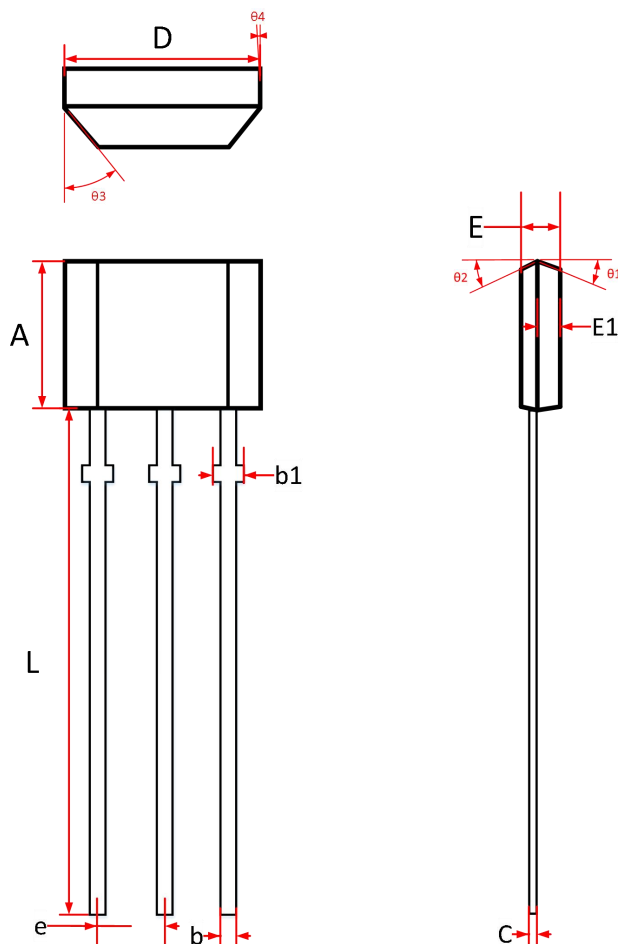

Symbol	Dimensions in Millimeters		
	Min.	Typ.	Max.
A	2.90	3.00	3.10
b	0.35	0.39	0.50
b1	0.40	0.44	0.55
C	0.36	0.38	0.45
D	3.90	4.00	4.10
E	1.42	1.52	1.62
E1		0.75	
e	1.27 TYP		
L	13.50	14.50	15.50
$\theta 1$		6°	
$\theta 2$		3°	
$\theta 3$		45°	
$\theta 4$		3°	